



SEBASTIAN ZELONKA PORTFOLIO

2010

CEB

www.executiveboard.com

- . ux research in collaboration with CEB team**
- . wireframes**
- . ui design**
- . IOS assets**



**CORPORATE
EXECUTIVE
BOARD**

TM

WHAT THE BEST COMPANIES DO



EXECUTIVE GUIDANCE FOR 2011



Turning **Ethics** into Outcomes

Focus on Three Steps to Manage Risk and Drive Performance. Order our e-book today.

MY QUESTIONS

Talent Matters: How to Stay Healthy for Work and 'Life'

Talent Matters: How to Stay Healthy for Work and 'Life'

[MORE](#)

MY DISCUSSIONS FORUMS

CLC HR Business Partner Forum **1**

Enterprise Architecture Forum **2**

[MORE](#)
[ASK A QUESTION](#)

FEATURED POST



Talent Matters: How to Network Effectively

The phrase "good networker" conjures up many mental images, and most of them are not positive: fake, pushy people who are only interested in you because they want a job or they want to sell you something.



Customer Service in the News Week of May 2

Many organizations use the gaps between execution and customer expectation as the roadmap for experience design, but fail to determine how the experience can be used to differentiate from competitors.

10 Habits of Highly Effective Social Media Marketers

Many organizations use the gaps between execution and customer expectation as the roadmap for experience design, but fail to determine how the experience.

Supply Chain: Complexity Versus Responsiveness

Supply Chain: Complexity Versus Responsiveness

The 2011 corporate growth agenda has refreshed a long-standing supply chain argument: one side thinks the firm should SKU expansion and customization.

Supply Chain: Complexity Versus Responsiveness

The 2011 corporate growth agenda has refreshed a long-standing supply chain argument: one side thinks the firm should SKU expansion and customization.

Customer Service in the News Week of May 2





Ask CEB



Discussions



Search Questions



MY FORUMS

EDIT FORUMS

DIGITAL MEDIA FORUM

Games on company website

Assessing leaders for global management responsibility

Leveraging Earned Media in Other Communications/Touchpoints

Supplier Diversity and Marketing

Best Practices on Translating Marketing

MARKETING ORG AND OPS FORUM

LEAD GENERATION FORUM

ASK A QUESTION

A-

A+

Nancy-Jo Nunez, Cisco Systems, Inc.

Asked on 4 February



I am part of a learning and development cohort within the Talent Management group of a manufacturing firm that does business in Asia and Africa. We've historically had a difficult time in assessing the skills of our senior executives with regard to global management. What steps have others taken when faced with this problem? Do you have similar issues in your company? How formal are these assessments?

Poll: Assessing leaders for global management responsibility

Has your call volume increased, decreased, or stayed the same?

Increased



Decreased

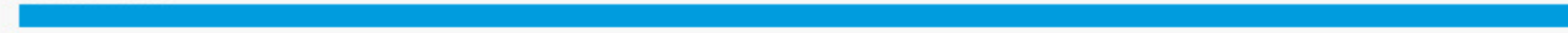

Stay The Same



Answers from the Network

Rick Sellers, Director Global Learning & Leadership Development

Replied on 7 February

The first thing to look at is general leadership ability, including among other things strong ability to adapt one's leadership style, to empathize with other cultures and be able to shift one's point of view; a strong inclination to reach out to others with excellent two-way communication skills. If you can identify the cultures involved, the use of something like the Cultural Orientations Indicator from TMC (www.tmc.org) can be useful. Demonstrated experience and interest in global cultures through travel





INSIGHTS

[Can Consumers Pull Out of the Slump?](#)[The New Customer Purchase Process](#)[10 Habits of Highly Effective Social Media Marketers](#)[Building Sustainable Brand Advocacy](#)[Reflections from 3 All-Star New Media Ringmasters](#)[How Pfizer Maps the Future](#)[What Makes the Apple Store Sweet](#)[Three Elements of a Strong Social Media Policy](#)[How is your program structured and what's](#)

Friday, April 15th, 2011

Posted by **Ben Eisen**

RELATED MATERIAL

RELATED DISCUSSIONS



A-

A+



10 Habits of Highly Effective Social Media Marketers

The one truism that seems to have weathered the downturn and on-again, off-again economic "recovery" is that the globalization of markets will continue at a steady forward pace and, therefore, so must our marketing capabilities to reach them. Just this past week, AdAge even proclaimed that a "tipping point" had been reached in the number of CMOs having a true global scope of responsibility.

Whether or not we are in fact at a watershed moment in global marketing leadership is up for debate, but most of us as marketers can agree that the decades-long trend of expanding into new markets is increasingly set against the backdrop of trying to create a more tightly knit global marketing organization. More and more marketer roles with a pan-geographic focus are surfacing in our conversations with members. Marketing processes are incorporating a more diverse range of inputs from across organizations' geographic footprint. Resource allocation post-credit crisis tends to be more reflective of countries' future opportunity versus simply our historical habit of investment.

But amid all of this progress, marketers tell us that they still struggle to see substantial gains in global marketing integration. One member recently commented, "the discussion internally has clearly shifted toward capitalizing on the scale of our international marketing operations but, if anything, it seems that we're moving further and further apart."



2013

Flowics

www.flowics.com

- User Research
- Need Findings
- Wireframes
- UI Design
- HTML + CSS

Lorem Ipsum is simply dummy text of the printing and typesetting industry. Lorem Ipsum has been the industry's standard dummy text ever since the 1500s, when an unknown printer took a galley of type and scrambled it to make a type specimen book.

[Nueva Visualización](#)

VISUALIZACIONES PREVIAS

Nombre	Fecha de creación	Acciones
● Nombre de la visualización	26-03-2012	Stop Edit Flow Moderate Preview Delete
● Nombre de la visualización	26-03-2012	Stop Edit Flow Moderate Preview Delete
● Nombre de la visualización	26-03-2012	Start Edit Flow Moderate Preview Delete

#LiberenLosLibros



TITULO DE LA VISUALIZACION

Lorem ipsum dolor sit amet, consectetur adipiscing elit. Phasellus eleifend ornare quam, vitae dignissim nisi pellentesque non. Vestibulum in ipsum ligula. Maecenas adipiscing auctor arcu, vitae ornare eros cursus eget. Nam fringilla ultrices risus, eu dignissim nisi bibendum ac.



@ El minuto a minuto

- >Lorem ipsum dolor sit amet, consectetur adipiscing elit. Phasellus eleifend ornare quam, vitae dignissim nisi pellentesque non. Vestibulum.
- >Lorem ipsum dolor sit amet, consectetur adipiscing elit. Phasellus eleifend ornare quam, vitae dignissim nisi pellentesque non. Vestibulum.
- >Lorem ipsum dolor sit amet, consectetur adipiscing elit. Phasellus eleifend ornare quam, vitae dignissim nisi pellentesque non. Vestibulum.
- >Lorem ipsum dolor sit amet, consectetur adipiscing elit. Phasellus eleifend ornare quam, vitae dignissim nisi pellentesque non. Vestibulum.
- >Lorem ipsum dolor sit amet, consectetur adipiscing elit. Phasellus eleifend ornare quam, vitae dignissim nisi pellentesque non. Vestibulum.

Tuitea tu opinion

Términos más usados

EDUCACION PLOMO
TECNOLOGÍA CULTURA
MORENO TECNOLOGÍA
 PLOMO PLOMO CULTURA PLOMO

Multimedia

156 archivos

@Los más compartidos

- >Lorem ipsum dolor sit amet, consectetur adipiscing elit. Phasellus eleifend ornare quam, vitae dignissim nisi pellentesque non. Vestibulum.
- >Lorem ipsum dolor sit amet, consectetur adipiscing elit. Phasellus eleifend ornare quam, vitae dignissim nisi pellentesque non. Vestibulum.
- >Lorem ipsum dolor sit amet, consectetur adipiscing elit. Phasellus eleifend ornare quam, vitae dignissim nisi pellentesque non. Vestibulum.
- >Lorem ipsum dolor sit amet, consectetur adipiscing elit. Phasellus eleifend ornare quam, vitae dignissim nisi pellentesque non. Vestibulum.
- >Lorem ipsum dolor sit amet, consectetur adipiscing elit. Phasellus eleifend ornare quam, vitae dignissim nisi pellentesque non. Vestibulum.

Los más tuiteros

- @TwitterNameMuyLargo 1250 tweets
- @TwitterNameMuyLargo 1250 tweets
- @TwitterNameMuyLargo 1250 tweets
- @TwitterNameMuyLargo 1250 tweets
- @TwitterNameMuyLargo 1250 tweets

#LiberenLosLibros



TITULO DE LA VISUALIZACION

Lorem ipsum dolor sit amet, consectetur adipiscing elit. Phasellus eleifend ornare quam, vitae dignissim nisi pellentesque non. Vestibulum in ipsum ligula. Maecenas adipiscing auctor arcu, vitae ornare eros cursus eget. Nam fringilla ultrices risus, eu dignissim nisi bibendum ac.



@Los más compartidos

- >Lorem ipsum dolor sit amet, consectetur adipiscing elit. Phasellus eleifend ornare quam, vitae dignissim nisi pellentesque non. Vestibulum.
- >Lorem ipsum dolor sit amet, consectetur adipiscing elit. Phasellus eleifend ornare quam, vitae dignissim nisi pellentesque non. Vestibulum.
- >Lorem ipsum dolor sit amet, consectetur adipiscing elit. Phasellus eleifend ornare quam, vitae dignissim nisi pellentesque non. Vestibulum.
- >Lorem ipsum dolor sit amet, consectetur adipiscing elit. Phasellus eleifend ornare quam, vitae dignissim nisi pellentesque non. Vestibulum.
- >Lorem ipsum dolor sit amet, consectetur adipiscing elit. Phasellus eleifend ornare quam, vitae dignissim nisi pellentesque non. Vestibulum.

Tweets recientes

- >Lorem ipsum dolor sit amet, consectetur adipiscing elit. Phasellus eleifend ornare quam, vitae dignissim nisi pellentesque non. Vestibulum.
- >Lorem ipsum dolor sit amet, consectetur adipiscing elit. Phasellus eleifend ornare quam, vitae dignissim nisi pellentesque non. Vestibulum.
- >Lorem ipsum dolor sit amet, consectetur adipiscing elit. Phasellus eleifend ornare quam, vitae dignissim nisi pellentesque non. Vestibulum.
- >Lorem ipsum dolor sit amet, consectetur adipiscing elit. Phasellus eleifend ornare quam, vitae dignissim nisi pellentesque non. Vestibulum.
- >Lorem ipsum dolor sit amet, consectetur adipiscing elit. Phasellus eleifend ornare quam, vitae dignissim nisi pellentesque non. Vestibulum.

@Los más tuiteros

- @nombreDelTuitero
- @nombreDelTuitero
- @nombreDelTuitero
- @nombreDelTuitero
- @nombreDelTuitero

Términos más usados

EDUCACION PLOMO
TECNOLOGÍA CULTURA
MORENO TECNOLOGÍA
 PLOMO PLOMO CULTURA PLOMO

Links destacados

1. <http://www.lanacion.com.ar/14603...>
2. <http://www.lanacion.com.ar/1460...>
3. <http://www.lanacion.com.ar/1658...>
4. <http://www.lanacion.com.ar/146...>

Multimedia

156 archivos

Tuitea tu opinion

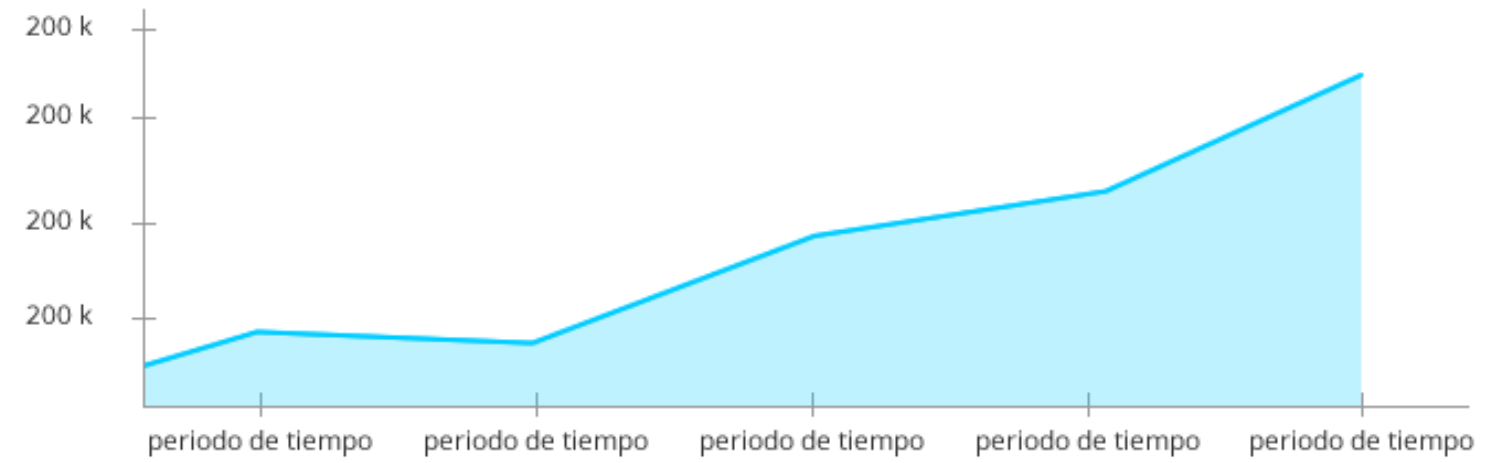
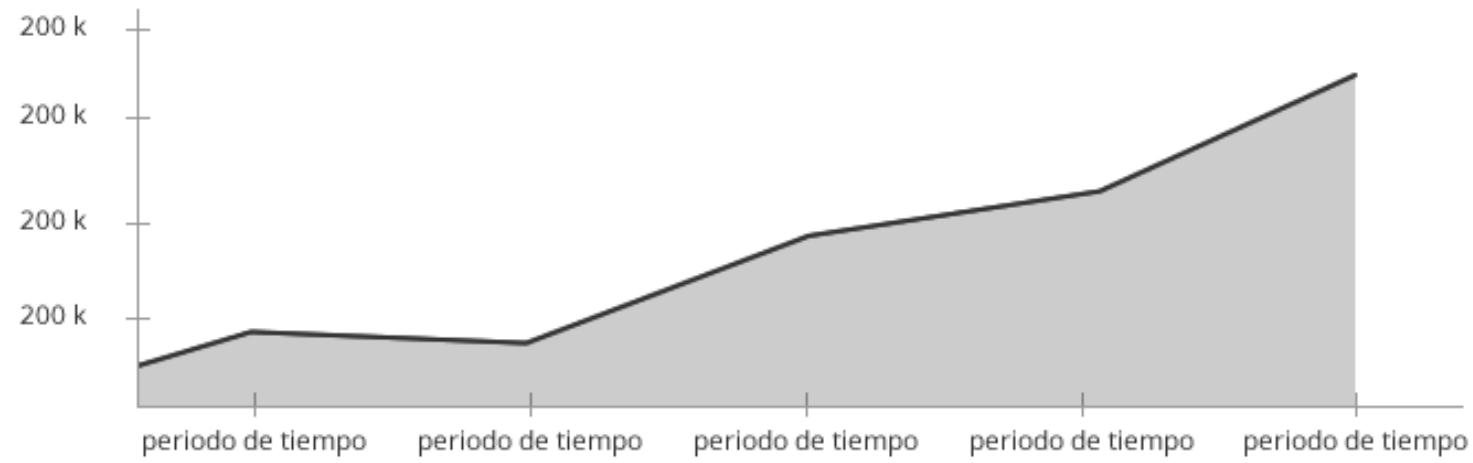

@ El minuto a minuto

Lorem ipsum dolor sit amet, consectetur adipiscing elit. Phasellus eleifend ornare quam, vitae dignissim nisl pellentesque non. Vestibulum.

Lorem ipsum dolor sit amet, consectetur adipiscing elit. Phasellus eleifend ornare quam, vitae dignissim nisl pellentesque non. Vestibulum.

Lorem ipsum dolor sit amet, consectetur adipiscing elit. Phasellus eleifend ornare quam, vitae dignissim nisl pellentesque non. Vestibulum.

Lorem ipsum dolor sit amet, consectetur adipiscing elit. Phasellus eleifend ornare quam, vitae dignissim nisl pellentesque non. Vestibulum.

Lorem ipsum dolor sit amet, consectetur adipiscing elit. Phasellus eleifend ornare quam, vitae dignissim nisl pellentesque non. Vestibulum.

Tuitea tu opinion

@Los más compartidos

Lorem ipsum dolor sit amet, consectetur adipiscing elit. Phasellus eleifend ornare quam, vitae dignissim nisl pellentesque non. Vestibulum.

Lorem ipsum dolor sit amet, consectetur adipiscing elit. Phasellus eleifend ornare quam, vitae dignissim nisl pellentesque non. Vestibulum.

Lorem ipsum dolor sit amet, consectetur adipiscing elit. Phasellus eleifend ornare quam, vitae dignissim nisl pellentesque non. Vestibulum.

Lorem ipsum dolor sit amet, consectetur adipiscing elit. Phasellus eleifend ornare quam, vitae dignissim nisl pellentesque non. Vestibulum.

Lorem ipsum dolor sit amet, consectetur adipiscing elit. Phasellus eleifend ornare quam, vitae dignissim nisl pellentesque non. Vestibulum.

@Los más compartidos

Lorem ipsum dolor sit amet, consectetur adipiscing elit. Phasellus eleifend ornare quam, vitae dignissim nisl pellentesque non. Vestibulum.

Lorem ipsum dolor sit amet, consectetur adipiscing elit. Phasellus eleifend ornare quam, vitae dignissim nisl pellentesque non. Vestibulum.

Lorem ipsum dolor sit amet, consectetur adipiscing elit. Phasellus eleifend ornare quam, vitae dignissim nisl pellentesque non. Vestibulum.

Lorem ipsum dolor sit amet, consectetur adipiscing elit. Phasellus eleifend ornare quam, vitae dignissim nisl pellentesque non. Vestibulum.

Lorem ipsum dolor sit amet, consectetur adipiscing elit. Phasellus eleifend ornare quam, vitae dignissim nisl pellentesque non. Vestibulum.

@Los más tuiteros

@nombreDelTuitero

@nombreDelTuitero

@nombreDelTuitero

@nombreDelTuitero

@nombreDelTuitero

TITULO DEL CHART

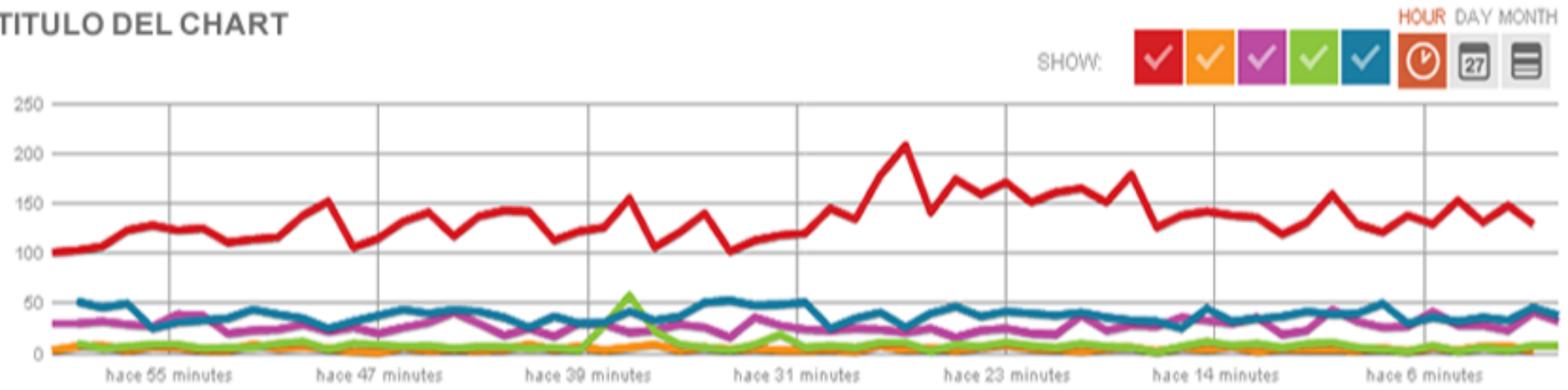

TITULO DEL CHART



TITULO DEL CHART

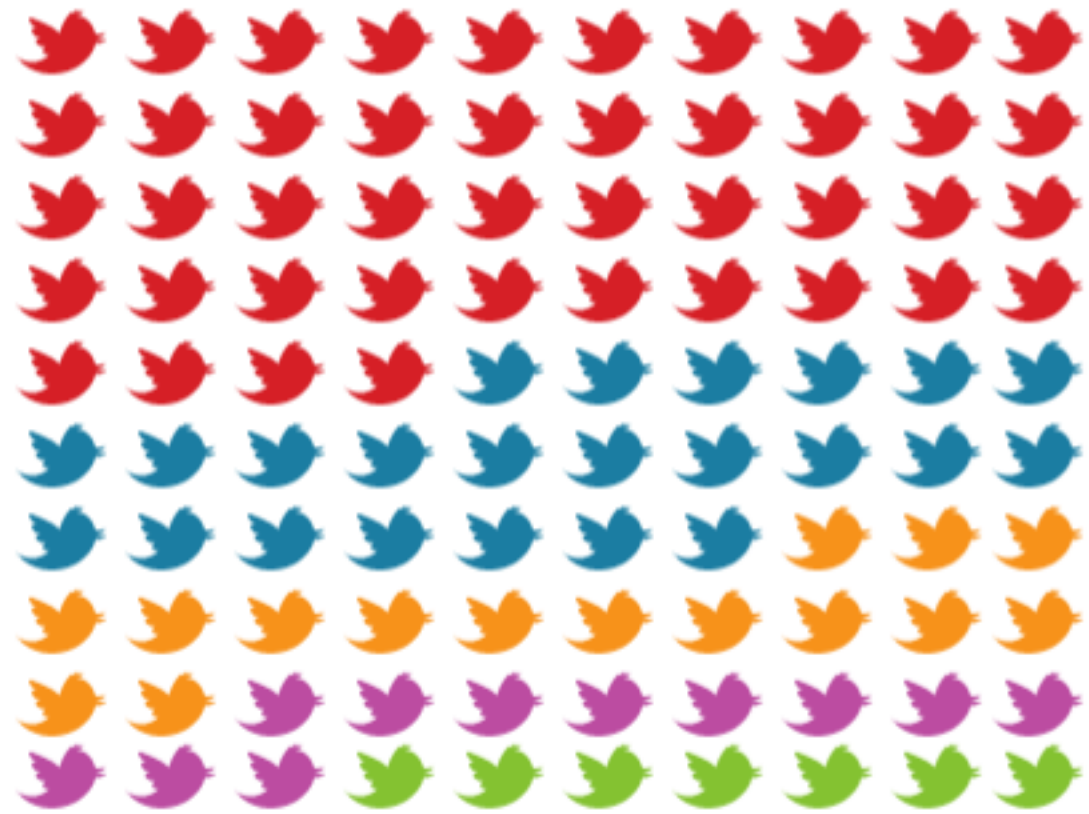

00%

Filter name

00%

Filter name

00%

Filter name

00%

Filter name

00%

Filter name



TwitterAccountName ▾

1.243.650
Followers ▲ 5,3%

10.243.650
Reach ▼ 0,8%

FOLLOWERS GROWTH ?

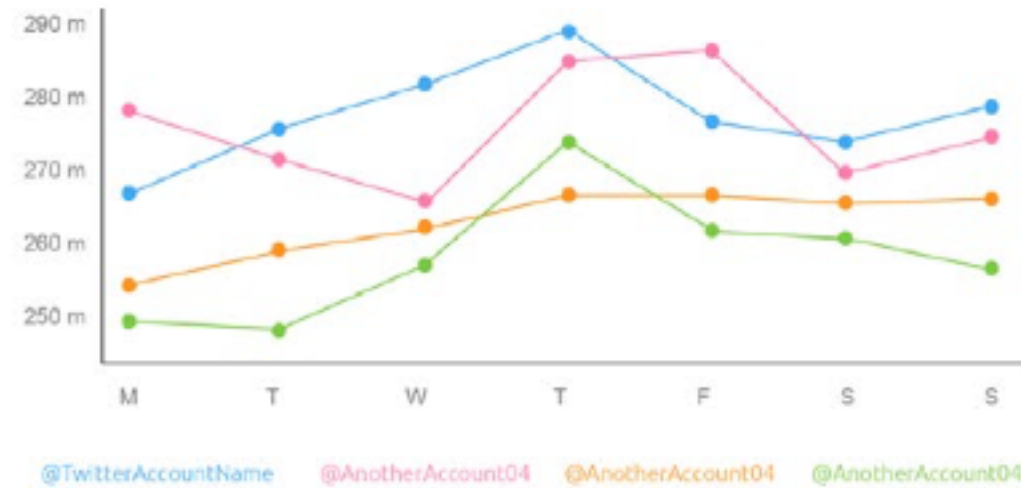

FOLLOWERS COMPOSITION ?

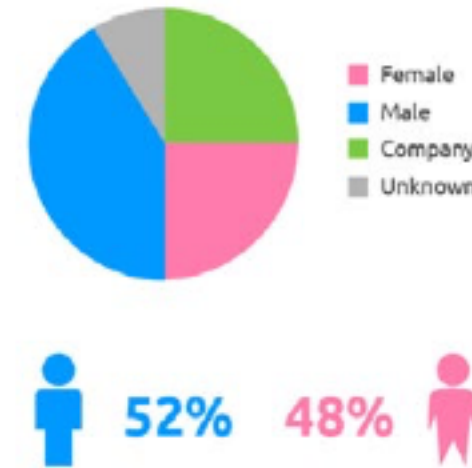

SOCIAL MEDIA IMMERSION ?



FOLLOWERS BY CITY ▾ ?

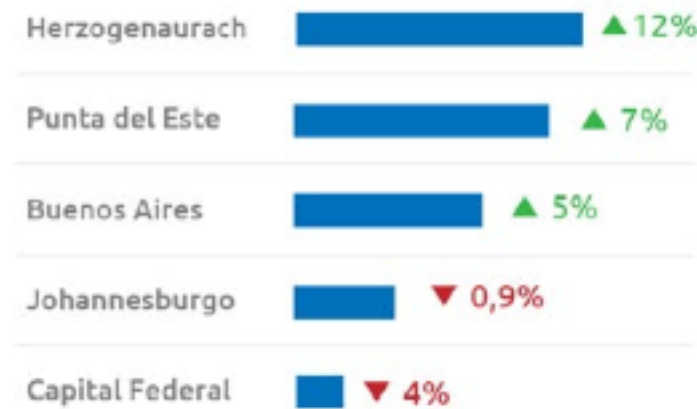

SHARED FOLLOWERS ?

USER	% SHARED
@AnotherAccount01	18%
@AnotherAccount02	11%
@AnotherAccount03	9%
@AnotherAccount04	3%
@AnotherAccount05	0,7%

RELEVANT FOLLOWERS ?

USER	FOLLOWERS	RATIO
@AnotherAccount01	1.525.430	0,3
@AnotherAccount02	525.430	0,5
@AnotherAccount03	325.446	0,1
@AnotherAccount04	165.298	0,3
@AnotherAccount05	65.430	0,8

LAST ACTIVITY ?

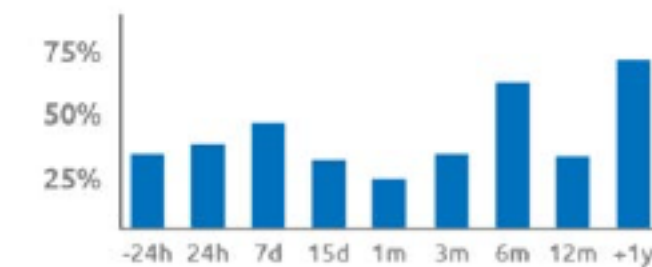

TIME ZONE ?



ACCOUNT AGE ?

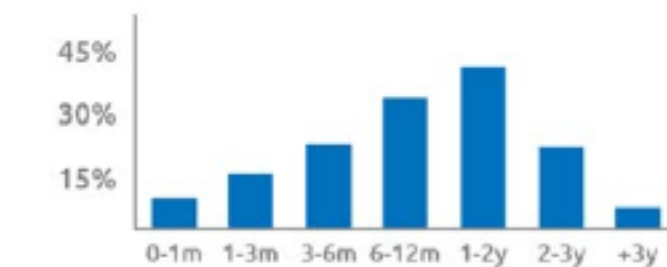

2012

Infobae

www.infobae.com

- UI Design
- HTML + CSS
- Phonegap
- Android + iOS assets





La ley de muerte digna podría ser debatida antes de fin de año en el Congreso

- Hoy - 2011-11-09 15:03:00

[Tweet](#) [Share](#) [Email](#)



En una reunión las comisiones General y Derecho de la Cámara de Diputados aprobó el proyecto presentado por Gerardo Milman. Podría tratarse de la sesión del próximo noviembre

Dicho proyecto es preparado para ser...

recinto durante la próxima sesión de la Cámara de Diputados que la semana anterior había sido también aprobado por la Comisión de Salud.

Milman consideró que "es un gran avance para nuestro país que un tema tan importante y delicado como este pueda ser debatido en el Congreso". "Dimos un paso más, esperemos seguir avanzando en el camino y poder contar con esta ley que beneficiará a una gran cantidad de personas", agregó.



Diputados: el FpV logró dictamen favorable para aprobar el Presupuesto 2012

- Hoy - 2011-11-09 00:19:00



[Compartir](#)

[Achicar](#)

[Agrandar](#)

iPad

12:15 PM

65%

infobae.com

Masiva protesta estudiantil en Londres



Decenas de miles de jóvenes británicos vuelven a marchar esta jornada por Londres en protesta del aumento de las matrículas universitarias anunciado la semana pasada por el gobierno de David Cameron



T-Mobile NL 12:33

4/10



Decenas de miles de jóvenes británicos vuelven a marchar esta jornada por Londres en protesta del aumento de las matrículas universitarias anunciado la semana pasada por el gobierno de David Cameron

2014

Aquicore

www.aquicore.com

- User Research
- User Testing
- Wireframes
- UI Design
- HTML + LESS in Angular

Operations ▾

Management

Trends

Scheduling

Weather

Alerts

kW ▾

Reports ▾

By Component Type

Dec 6, 2013 8:00 Week EST Dec 13, 2013 8:00

- Poplar Run
- BECO Fifty West

Fri Dec 6th - Dec 13th

158 EUI kW/SF/yr	1,311 Peak kW	51,434 Total kWh
----------------------------	-------------------------	----------------------------

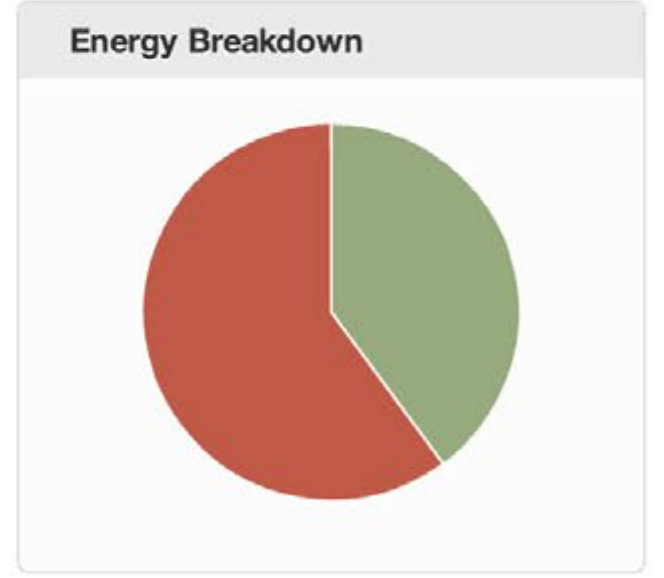
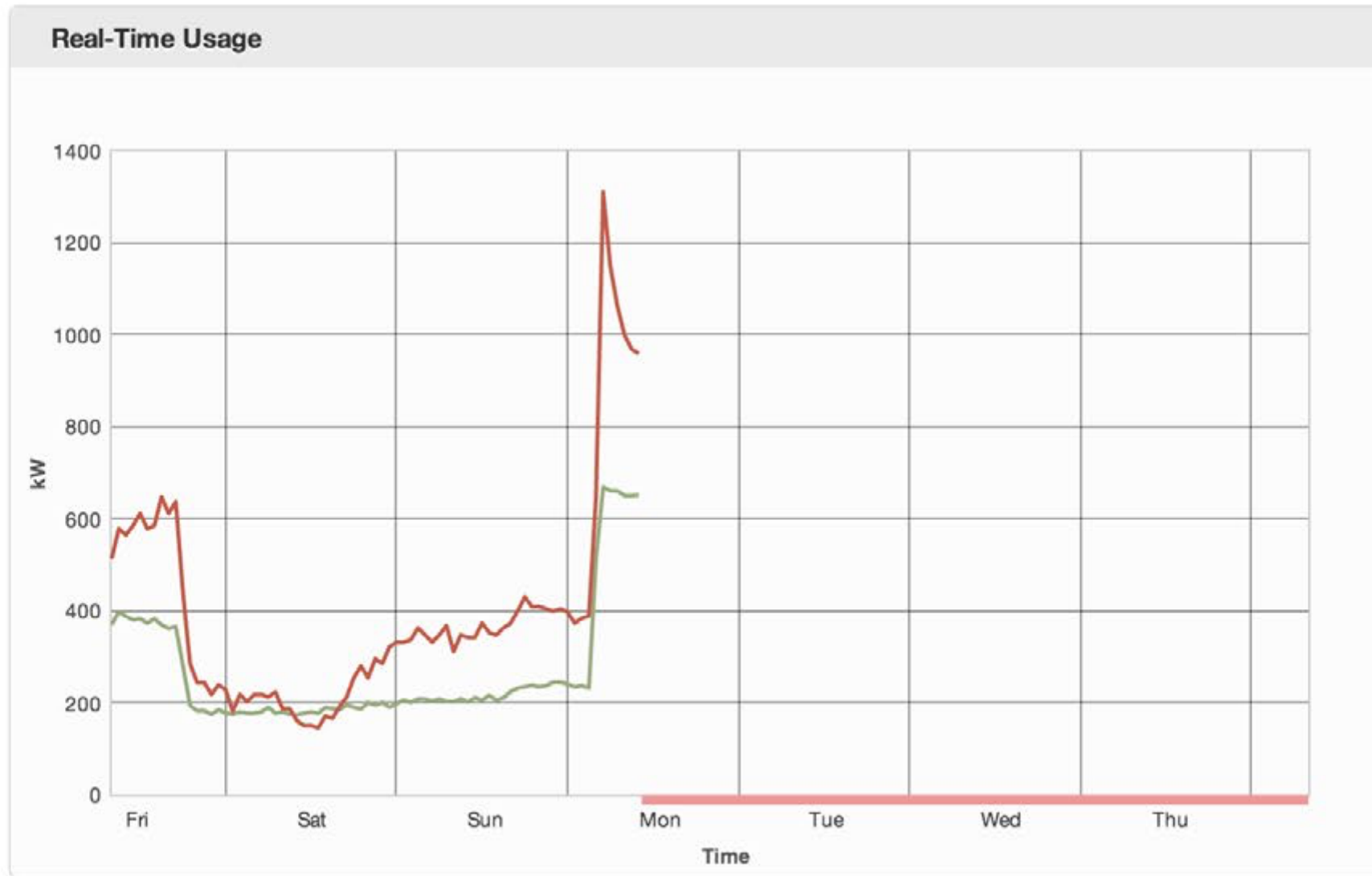

Highest Consumption

	BECO Fifty West	30,930 kWh
	Poplar Run	20,504 kWh

BY COMPONENT TYPE

Search building

OFFICES

DC LIBRARY

POPLAR RUN

FAIRFAX OFFICE GROUNDS

CITY HEADQUARTERS

SILICON TECH HQ

DC LIBRARY

POPLAR RUN

SCHOOL

FAIRFAX OFFICE GROUNDS

CITY HEADQUARTERS

SILICON TECH HQ

DC LIBRARY

POPLAR RUN

FAIRFAX OFFICE GROUNDS

CITY HEADQUARTERS

< > 1 YEAR ▼ OCT 20, 2013 - NOV 20, 2013 ▼

REPORTS ▼

 ALERTS **WEATHER** TRENDS SCHEDULE BENCHMARKS NORMALIZE

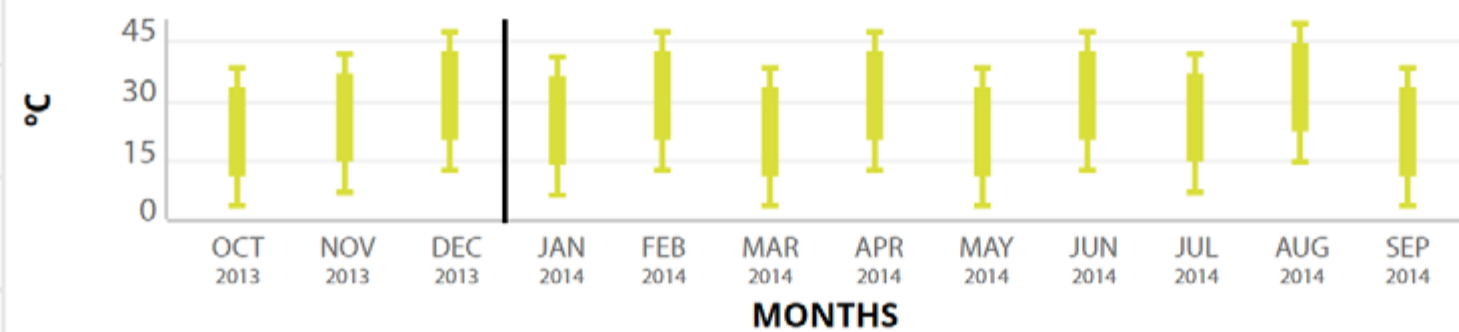
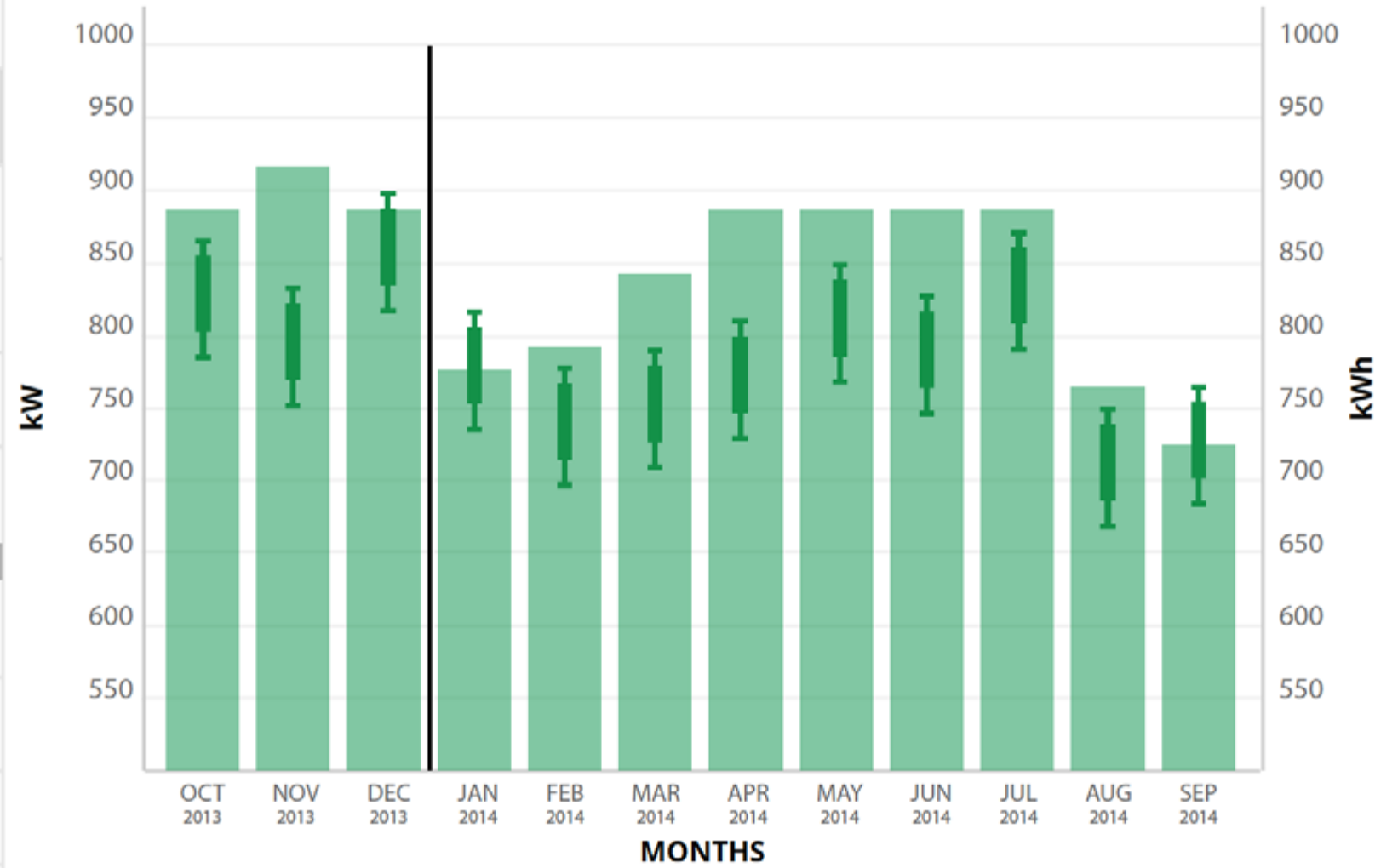
kW KWH WATER GAS

ENERGY STATS
29,563 Total kWh

 346 Peak kW

 82 EUI kW/SF/yr

WEATHER STATS

 HDD **0**

 CDD **26**

BACK



Master Electric

SETTINGS

INPUT ASSIGMENTS

METER ASSIGNMENTS

STATUS

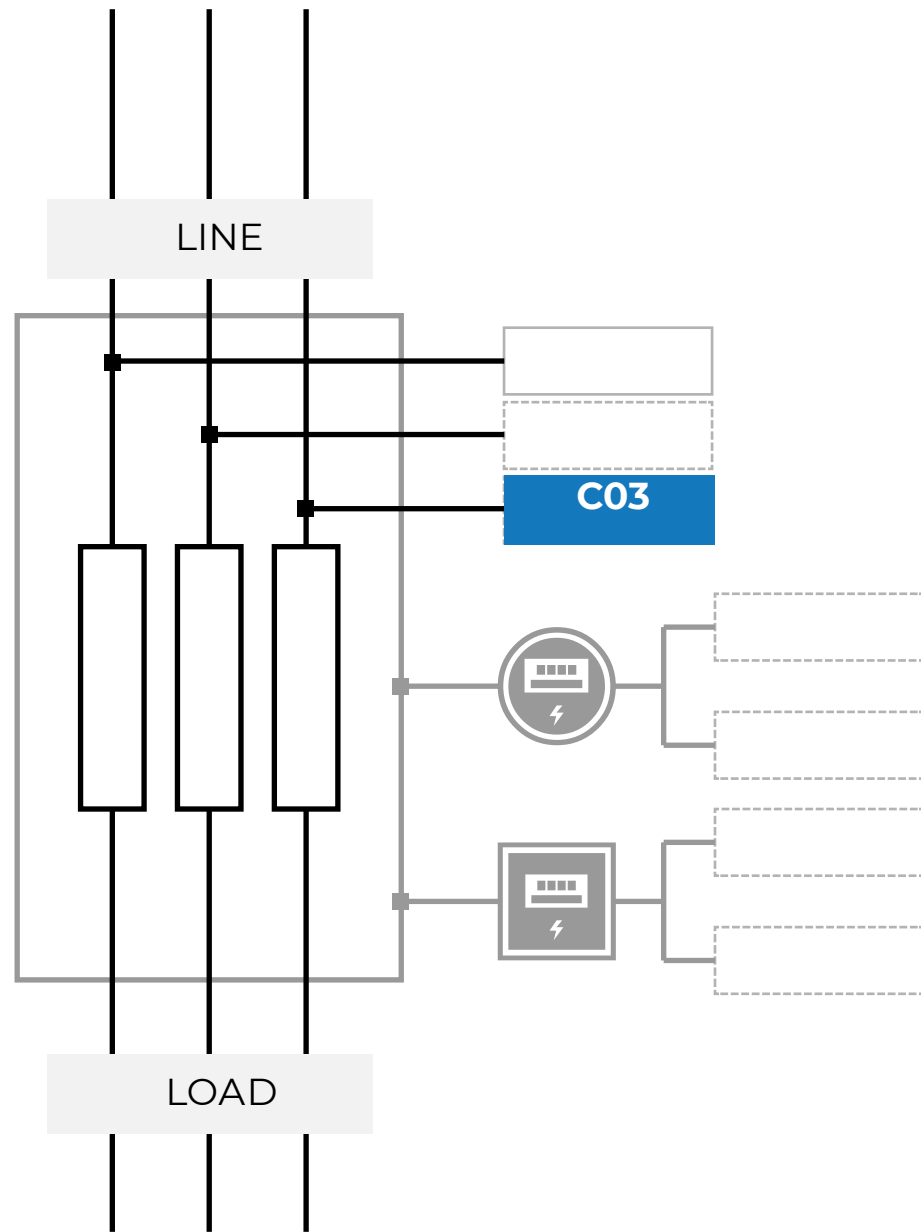

Connected meters

C01

C02

C04

C06

Energy Usage

Ways to Save Energy

Turn o
down and turn o
the night. **You could save \$120 for the month.**

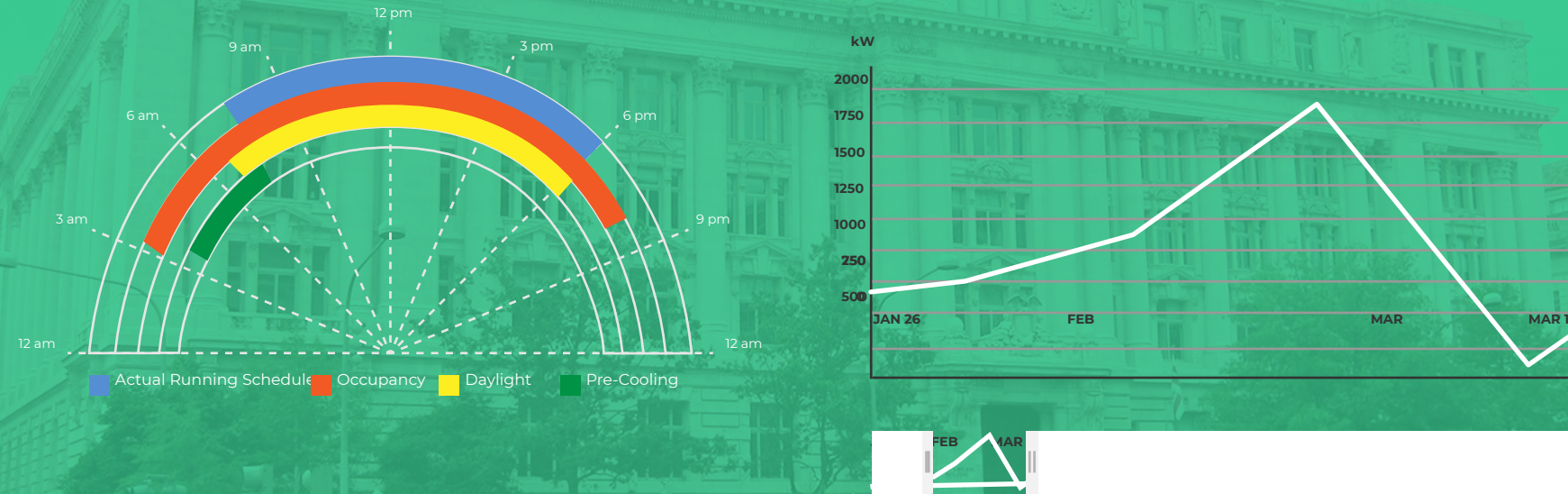

Woodrow Wilson High School

3950 CHESAPEAKE ST NW,
WASHINGTON, DC

As Washington's largest comprehensive public high school, Woodrow Wilson High School is home to a very diverse student population. In 2011, the entire campus underwent a complete \$105 million modernization just in time for their 75th anniversary. More than 9 out of 10 Wilson graduates attend college and members of last year's class were accepted to over 200 universities and



SHOW MORE

ENERGY PERFORMANCE FOR BUILDING NAME

SCORE
EUI **95**

BUILDING TYPE	High School
SIZE	376,507 SF
EUI (kBtu/SF/Yr)	95 EUI
ANNUAL ENERGY COST	\$717,435
ANNUAL ELECTRICITY USE	3,345,987 kWh
ANNUAL NATURAL GAS USE	298,543 Therms
ANNUAL GHG EMISSIONS	606 Tons
GAS AS % OF BTUS	71 %
GAS AS % OF ENERGY COST	41 %

ENVIRONMENTAL IMPACT



PEERS

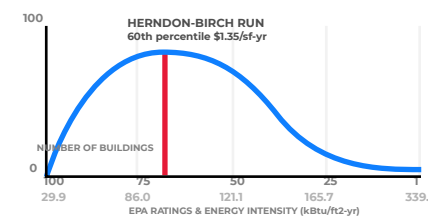

LAST DAY RECORDED

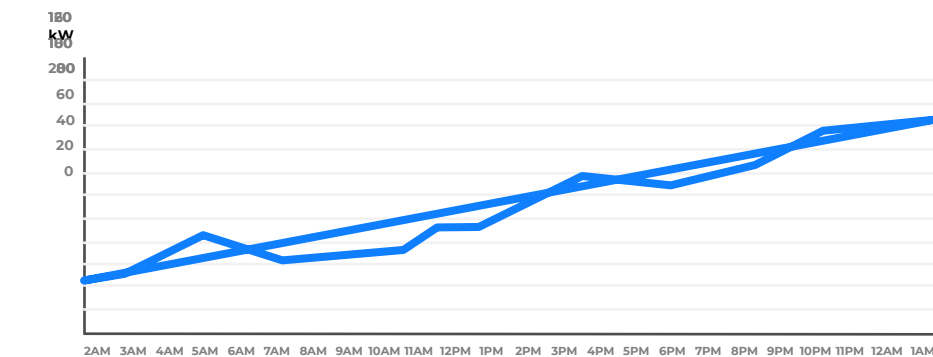

EXECUTIVE DASHBOARD

YEAR **53,900** kWh/car **18%**

Last Year: 83,860 kWh/car
EUI (kBtu/SF/Yr): 95 EUI
ANNUAL ENERGY COST: \$9,435,876
ANNUAL ELECTRICITY USE: 4,325,543 kWh

MONTH **75,900** kWh/car **8%**

Last Month: 63,860 kWh/car
EUI (kBtu/SF/Yr): 95 EUI
ENERGY COST: \$9,435,876
ELECTRICITY USE: 4,325,543 kWh

HIGHEST CONSUMPTION

- DRIVE UNITS: 83,779 kWh
- BATTERY PACKS: 54,029 kWh
- CARS THROUGH PAINT: 12,459 kWh
- FACTORY GATE: 2,224 kWh

ENERGY BREAKDOWN

- OTHERS
- FACTORY GATE
- CARS THROUGH PAINT
- BATTERY PACKS
- DRIVE UNITS

MONTHLY ENERGY USAGE

Y-axis: kWh (0 to 2000)

X-axis: JAN 20, JAN 21, JAN 22, JAN 23, JAN 24, JAN 25, JAN 26, JAN 27, JAN 28, JAN 29

EXECUTIVE DASHBOARD

YEAR **53,900** kWh/car **18%**

Last Year: 83,860 kWh/car
EUI (kBtu/SF/Yr): 95 EUI
ANNUAL ENERGY COST: \$9,435,876
ANNUAL ELECTRICITY USE: 4,325,543 kWh

MONTH **75,900** kWh/car **8%**

Last Month: 63,860 kWh/car
EUI (kBtu/SF/Yr): 95 EUI
ENERGY COST: \$9,435,876
ELECTRICITY USE: 4,325,543 kWh

HIGHEST CONSUMPTION

- DRIVE UNITS: 83,779 kWh
- BATTERY PACKS: 54,029 kWh
- CARS THROUGH PAINT: 12,459 kWh
- FACTORY GATE: 2,224 kWh

ENERGY BREAKDOWN

- OTHERS
- FACTORY GATE
- CARS THROUGH PAINT
- BATTERY PACKS
- DRIVE UNITS

MONTHLY ENERGY USAGE

Y-axis: kWh (0 to 2000)

X-axis: JAN 20, JAN 21, JAN 22, JAN 23, JAN 24, JAN 25, JAN 26, JAN 27, JAN 28, JAN 29

ANNUAL ENERGY SOURCES

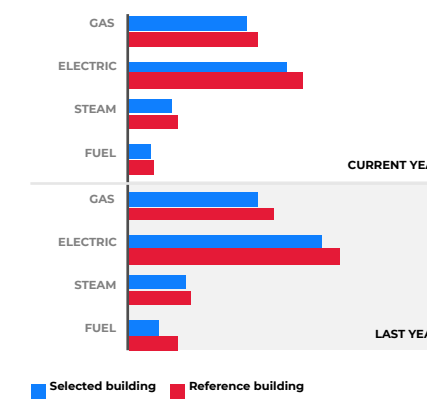

ELECTRICITY USAGE HISTORY

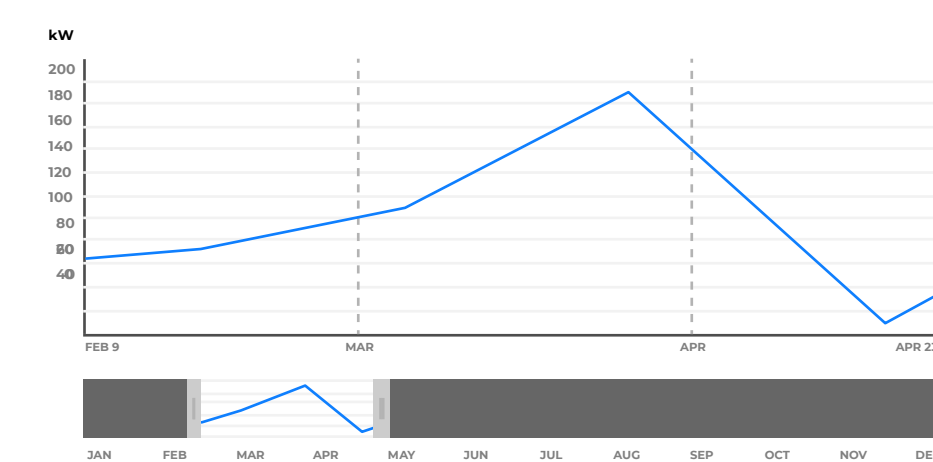

2015

Green Commuter

www.greencommuter.org

- User Research
- Personas
- Scenarios
- Wireframes
- Product Definition
- UI Design



Registration form with fields for email and password.

Terms and conditions text block.

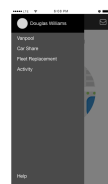

Personal info form with fields for name, phone, and address.

Address form with fields for street, city, and zip.

Vehicle info form with fields for make, model, and year.

Vehicle selection screen with a list of options.

Registration confirmation form.

Approval pending notification screen.

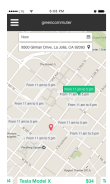

Table with columns for date, time, and status.

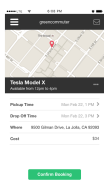
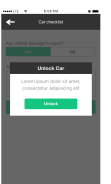
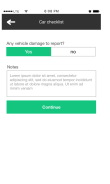
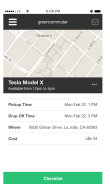
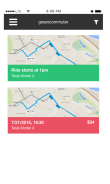
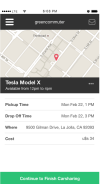

Table with columns for date, time, and status.



Form with a 'Check Car' button.



Form with a 'Check Car' button.

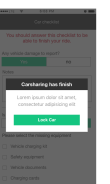

Form with a 'Check Car' button.

Form with a 'Check Car' button.

Form with a 'Check Car' button.



Personal info form.

Successful Authentication message.

Address form.

Vehicle info form.

Registration confirmation form.

Approval pending notification screen.



Table with columns for date, time, and status.

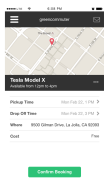
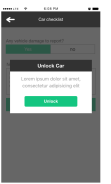
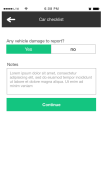
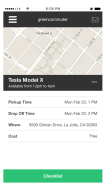
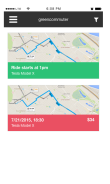
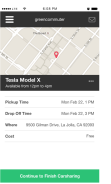

Table with columns for date, time, and status.



Form with a 'Check Car' button.



Form with a 'Check Car' button.

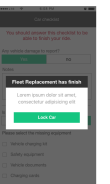

Form with a 'Check Car' button.

Form with a 'Check Car' button.

Form with a 'Check Car' button.

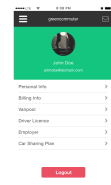

Profile details form.

Job info form.

Account info form.

Registration confirmation form.

Registration confirmation form.

My Vapour profile page.

Vehicle details form.

Registration confirmation form.

Registration confirmation form.

Registration confirmation form.

Registration confirmation form.

Registration confirmation form.

Registration confirmation form.

Registration confirmation form.

Registration confirmation form.

Registration confirmation form.

Registration confirmation form.

Registration confirmation form.

Registration confirmation form.

Registration confirmation form.

Registration confirmation form.

Terms and conditions text block.

Terms and conditions text block.

Terms and conditions text block.

Terms and conditions text block.

Terms and conditions text block.

Terms and conditions text block.

Terms and conditions text block.

Terms and conditions text block.

Terms and conditions text block.

Terms and conditions text block.

Terms and conditions text block.

Terms and conditions text block.

Terms and conditions text block.

Terms and conditions text block.

Terms and conditions text block.

Terms and conditions text block.

Terms and conditions text block.

Terms and conditions text block.

Terms and conditions text block.

Terms and conditions text block.

Terms and conditions text block.

Terms and conditions text block.

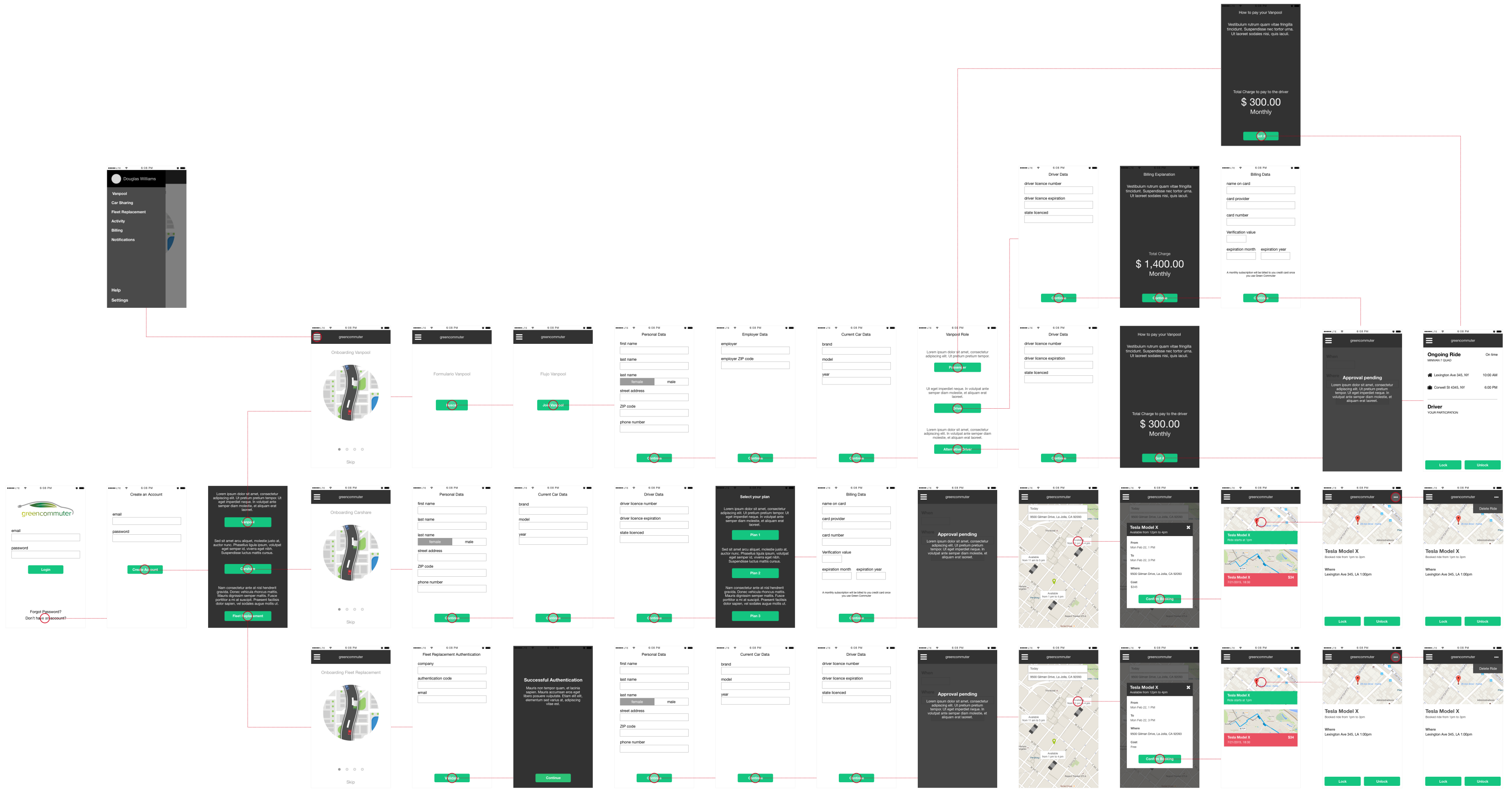

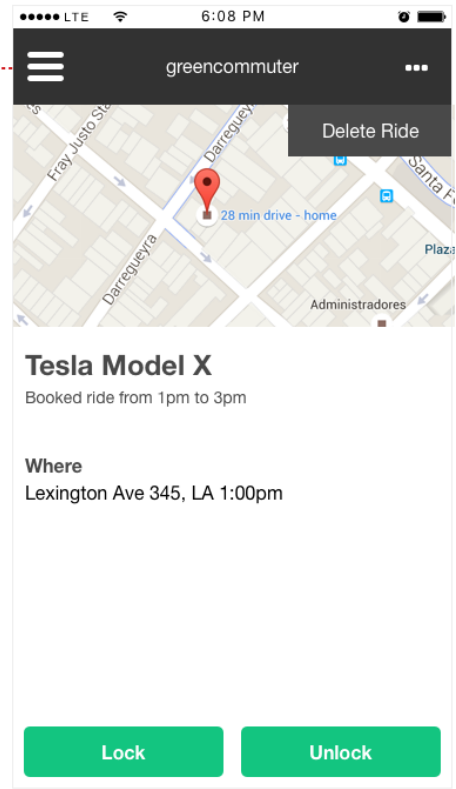
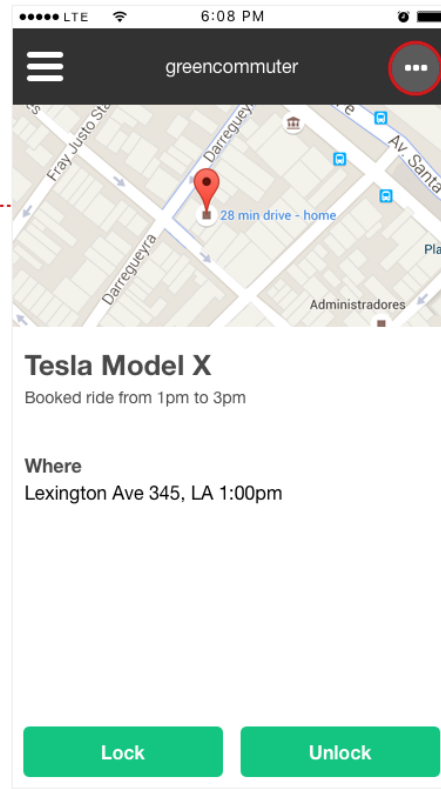
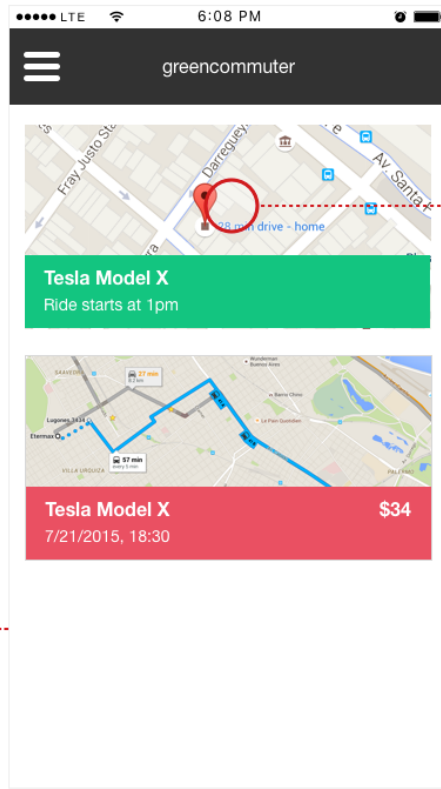
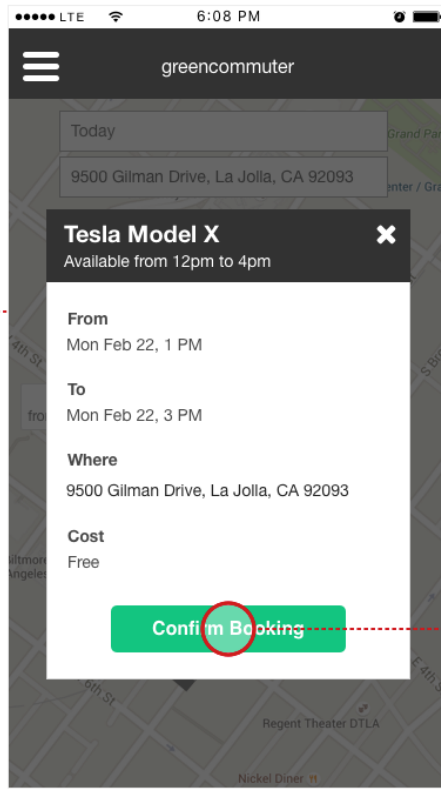
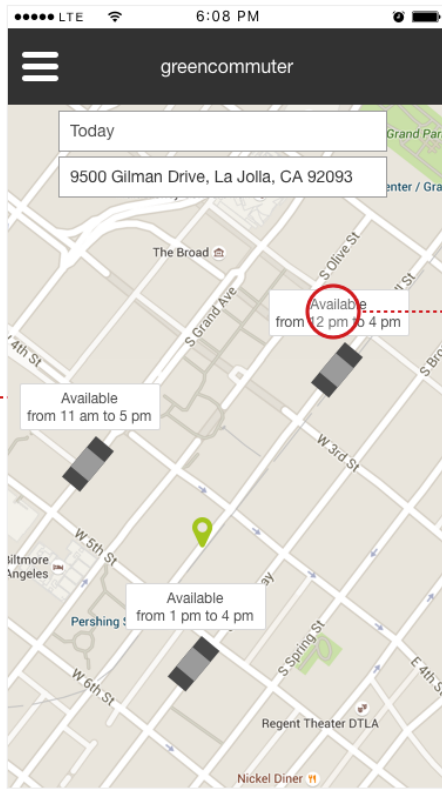
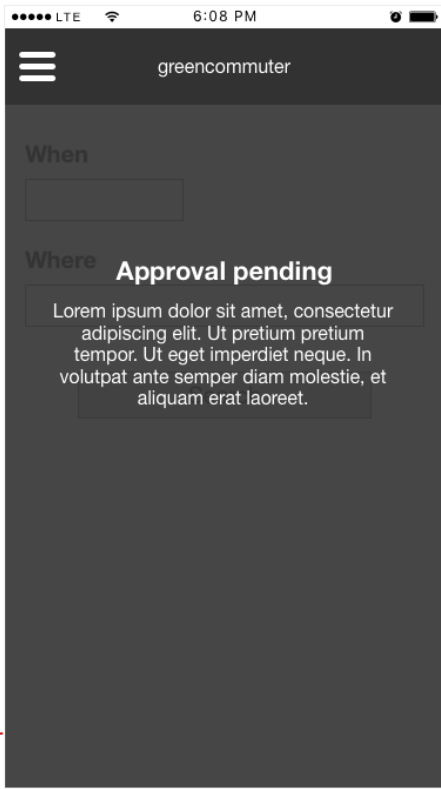
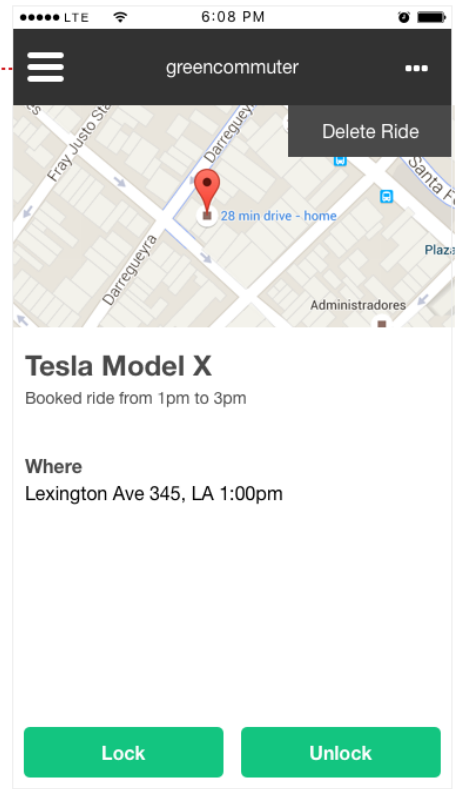
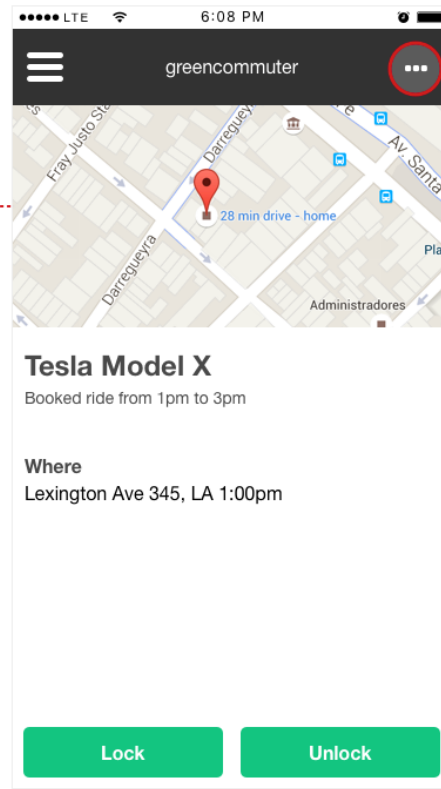
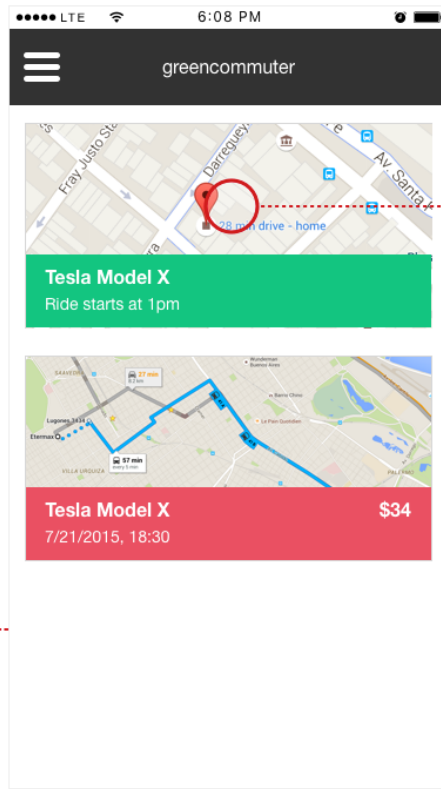
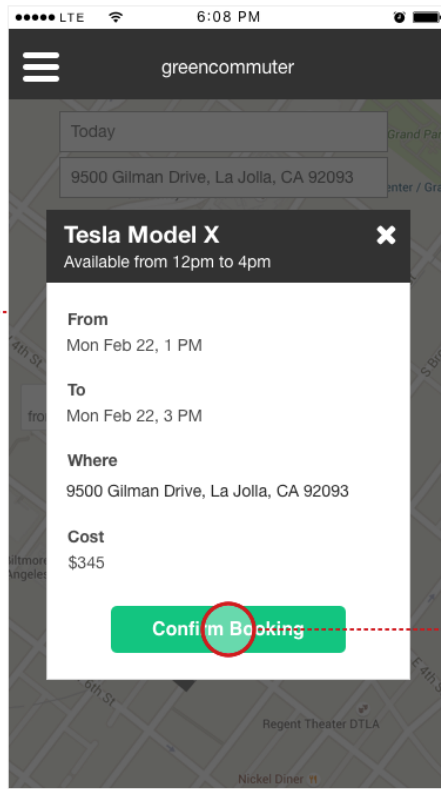
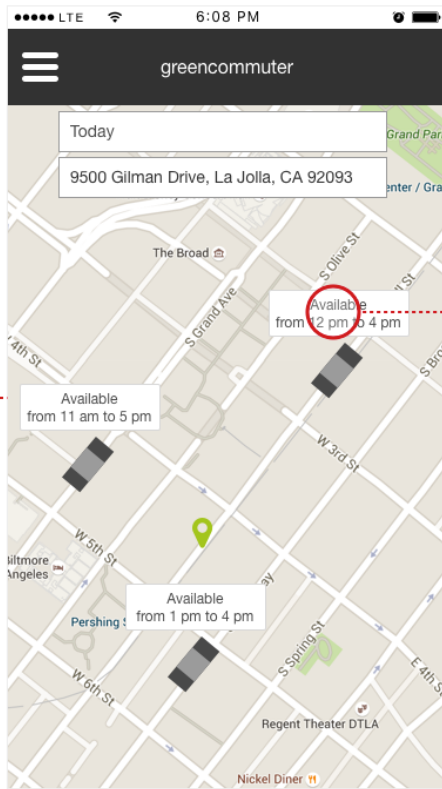
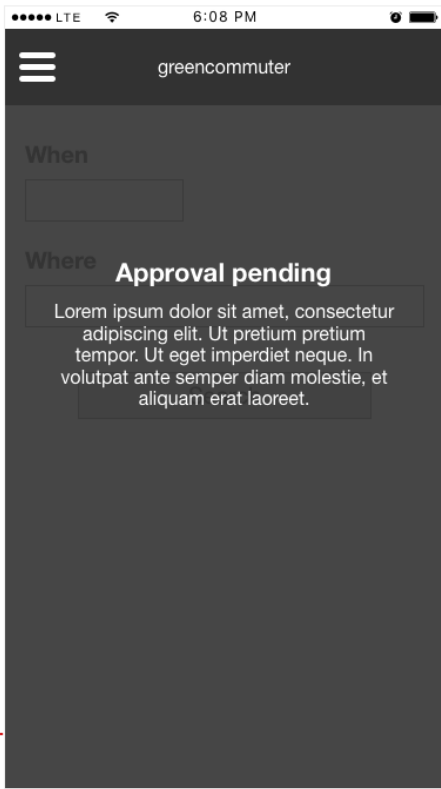

2016 - 2018

Onapsis

www.onapsis.com

- User Research
- Personas
- Product Design
- User Flows
- UI Design
- Usability Test



Risk Level i



Risk Level **35**

Risk Level Over Time i

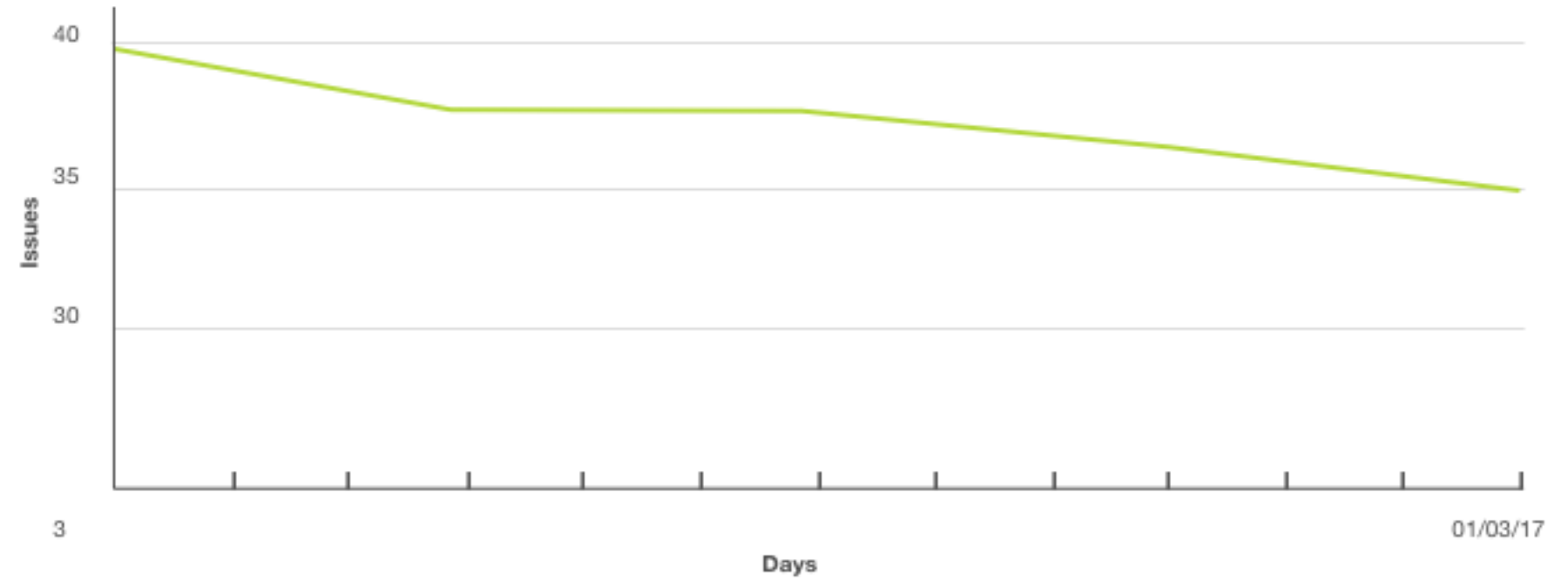

Issues and Alarms by Level Over Time i

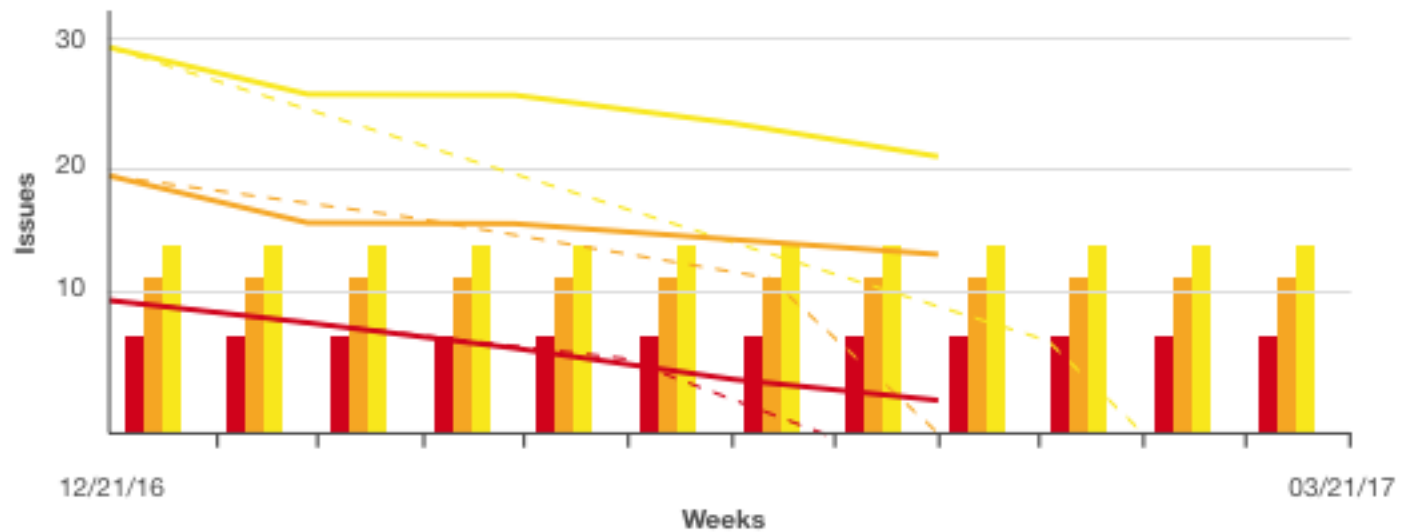

Last 10 alarms i

- Alarm Name Too Long Curabitur lobortis id lorem id bibendum. 🚩🚩🚩🚩🚩

Date Created Related OKB
- Alarm Name Too Long Curabitur lobortis id lorem id bibendum. 🚩🚩🚩🚩🚩

Date Created Related OKB
- Alarm Name Too Long Curabitur lobortis id lorem id bibendum. 🚩🚩🚩🚩🚩

Date Created Related OKB

Incidents

Incidents

Group by Severity

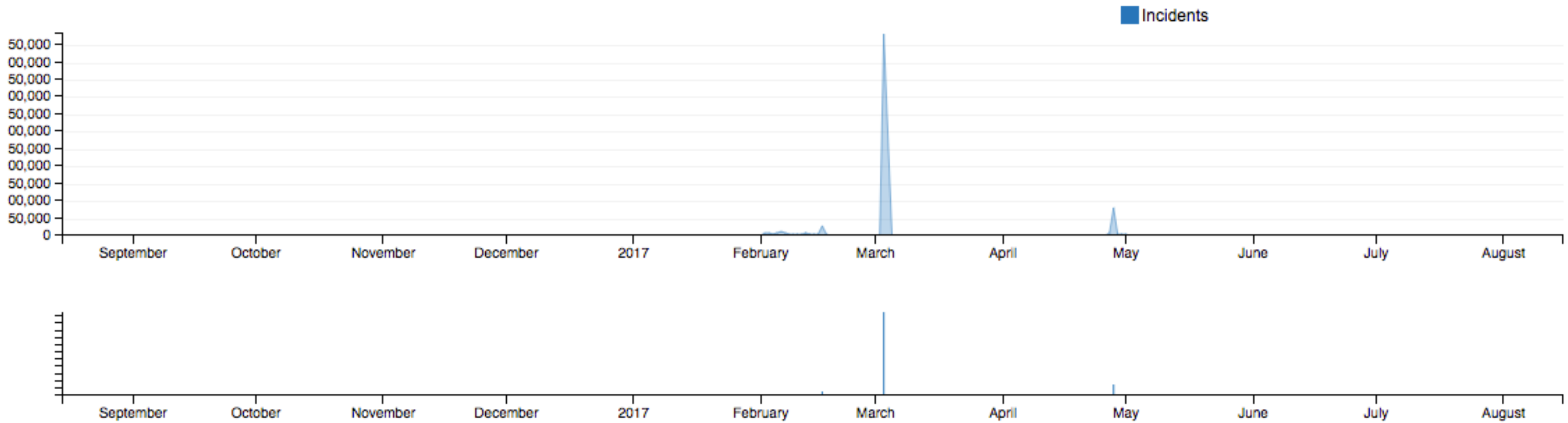

Type	Name	Triggered Date	Event Date	Affected Asset	Severity	Confidence	Action
Malware Signature	Dangerous PDF Document	2017-08-15 15:06:47	2017-08-15 15:06:47	10.10.10.1	High	Low	+
Malware Signature	Dangerous PDF Document	2017-08-15 15:06:47	2017-08-15 15:06:47	10.10.10.1	High	Low	+
Malware Signature	Dangerous PDF Document	2017-08-15 15:06:47	2017-08-15 15:06:47	10.10.10.1	High	Low	+
Malware Signature	Dangerous PDF Document	2017-08-15 15:06:47	2017-08-15 15:06:47	10.10.10.1	High	Low	+
Malware Signature	Dangerous PDF Document	2017-08-15 15:06:47	2017-08-15 15:06:47	10.10.10.1	High	Low	+
Malware Signature	Dangerous PDF Document	2017-08-15 15:06:47	2017-08-15 15:06:47	10.10.10.1	High	Low	+
Malware Signature	PDF_2017_08_15_15:02:10	2017-08-15 15:02:10	2017-08-15 15:02:10	10.10.10.1	High	High	+
Malware Signature	Dangerous PDF Document	2017-08-15 15:06:47	2017-08-15 15:06:47	10.10.10.1	High	Low	+

Incidents

Filter by

Date
 From To

Incident Name

Asset Name

Type

Severity
 Critical
 High
 Medium
 Low

Confidence
 High
 Medium
 Low
 Unknown

Filter Results

Event Date	Type	Incident Name	Incident Source	Asset Name	Severity	Confidence	Action
2017-03-15 15:00:47	Host Signature	Trusted network connection from untrusted host	192.168.1.100	HQ1	Critical	Unknown	View Detail
2017-03-15 15:36:18	User Activity	USB device	192.168.1.100	T74	Medium	Unknown	Medium
2017-03-15 15:00:47	User Activity	USB device	192.168.1.100	EP1	High	Medium	Critical
2017-03-15 15:40:21	Host Signature	Unloading of user profile	192.168.1.100	T71	Medium	Medium	High
2017-03-15 15:00:47	Host Signature	Dangerous WMI execution	192.168.1.100	EP1	High	Medium	High
2017-03-15 15:00:47	Host Signature	USB device	192.168.1.100	HQ1	Medium	High	Medium
2017-03-15 15:36:18	Host Signature	USB device	192.168.1.100	T71	Medium	High	Medium
2017-03-15 15:00:47	User Activity	Unloading of user profile	192.168.1.100	EP1	Medium	Low	Medium
2017-03-15 15:00:47	User Activity	Unloading of user profile	192.168.1.100	T74	Critical	Medium	Critical
2017-03-15 15:00:47	Host Signature	Unloading of user profile	192.168.1.100	HQ1	High	Low	Critical
2017-03-15 15:36:16	User Activity	USB device	192.168.1.100	EP1	High	Medium	High
2017-03-15 15:36:18	User Activity	Unloading of user profile	192.168.1.100	EP1	Low	High	Low
2017-03-15 15:36:16	Host Signature	USB device	192.168.1.100	EP1	Critical	High	Medium
2017-03-15 15:00:47	User Activity	USB device	192.168.1.100	HQ1	Medium	High	Medium
2017-03-15 15:00:47	User Activity	Unloading of user profile	192.168.1.100	HQ1	Medium	High	High
2017-03-15 15:00:47	Host Signature	USB device	192.168.1.100	T71	High	Low	Critical
2017-03-15 15:36:18	User Activity	USB device	192.168.1.100	T71	High	Medium	Critical

Add Asset Flow Old

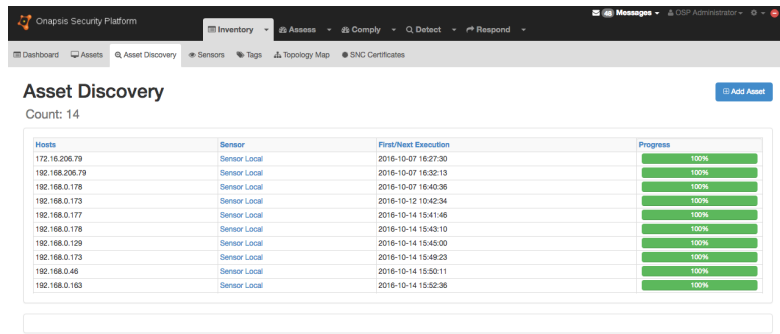

01 - Add asset

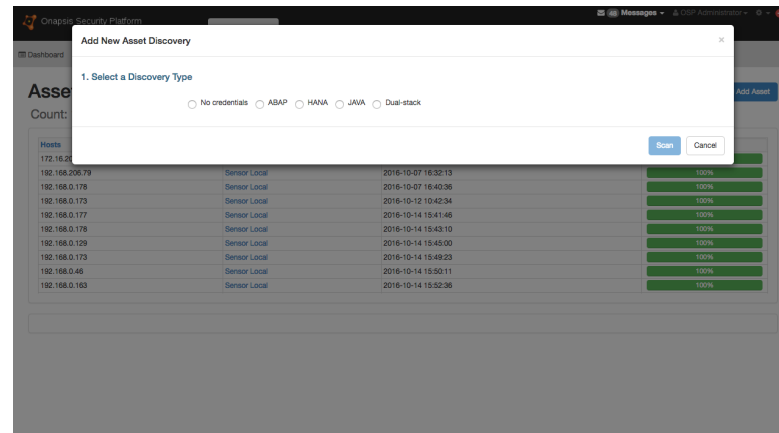

02 - Discovery Type

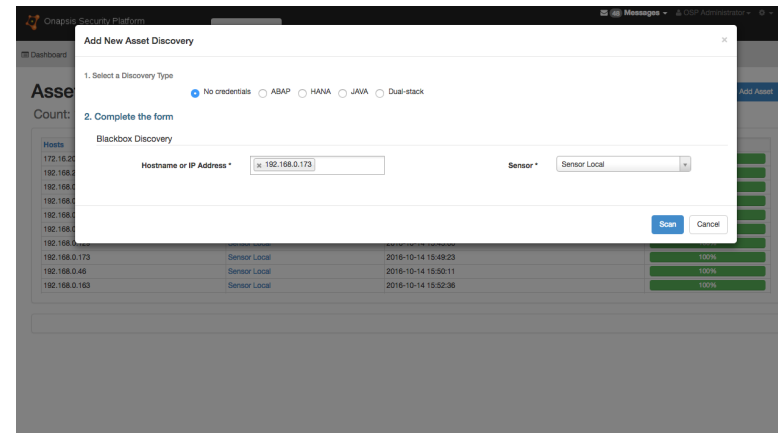

03 - Blackbox Discovery

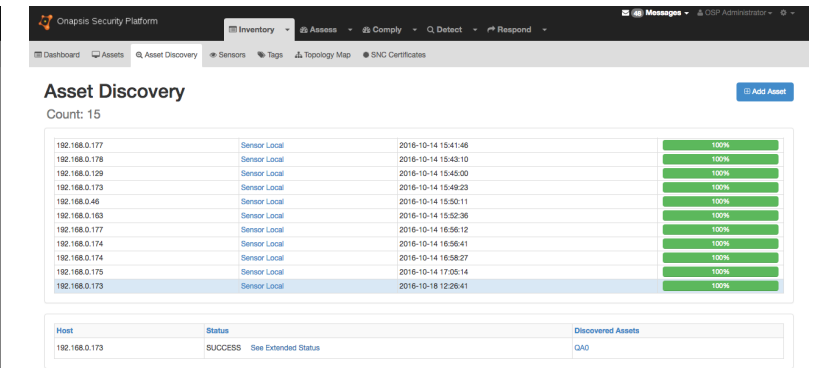

04 - Asset discovery finished

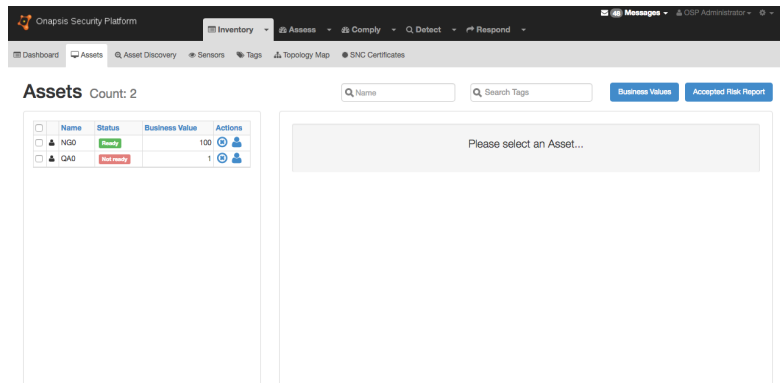

05 - Assets list

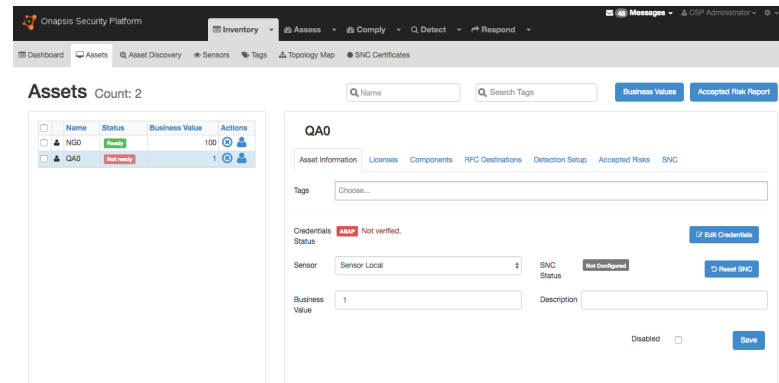

06 - Asset not ready / Not verified

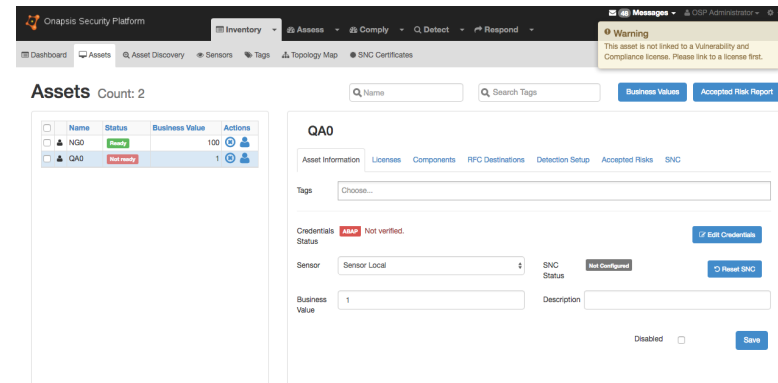

07 - Asset not linked to licence

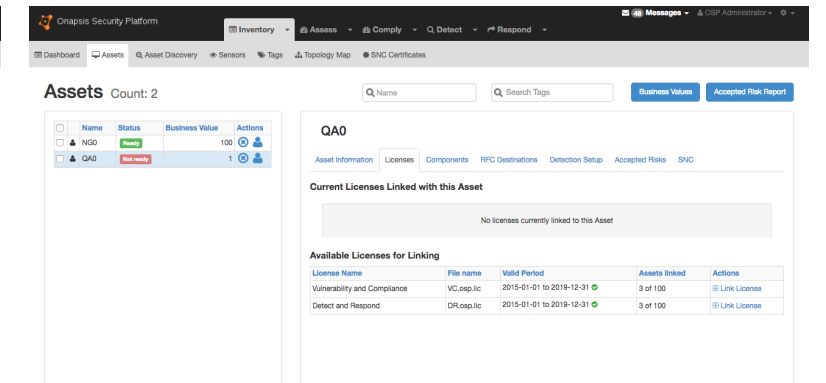

08 - Licences tab

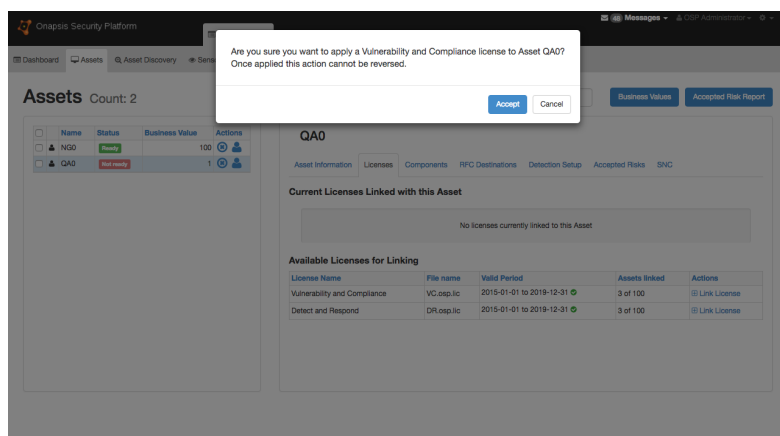

09 - Accept to link licence

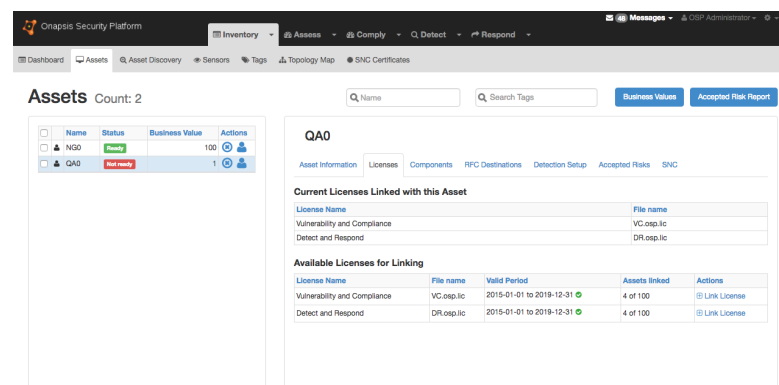

10 - Licences linked

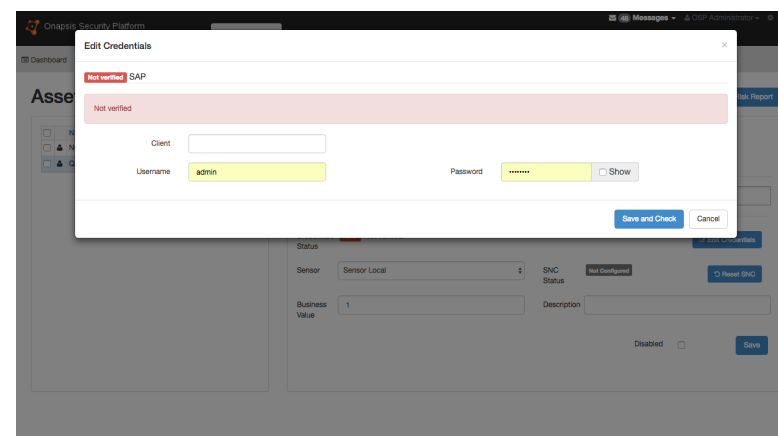

11 - Fix credential problems

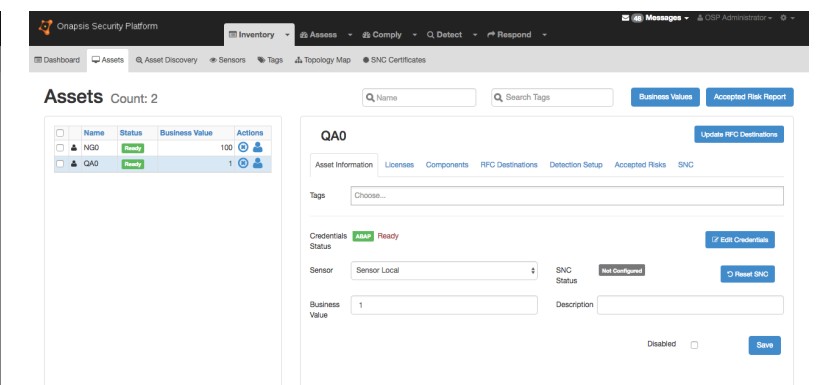

12 - Asset ready to use

Add Asset Flow Wireflow

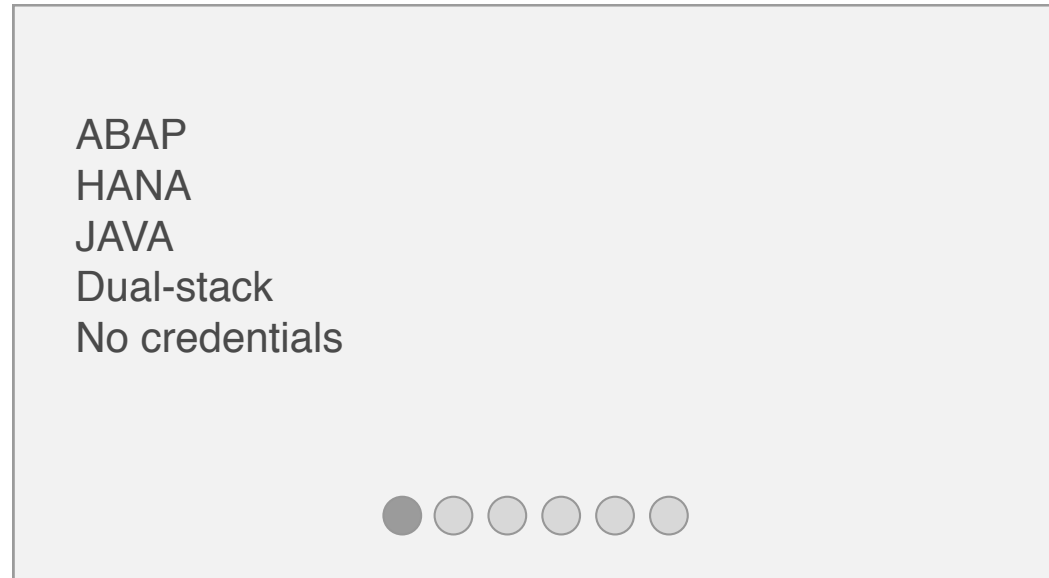

01- Discovery type

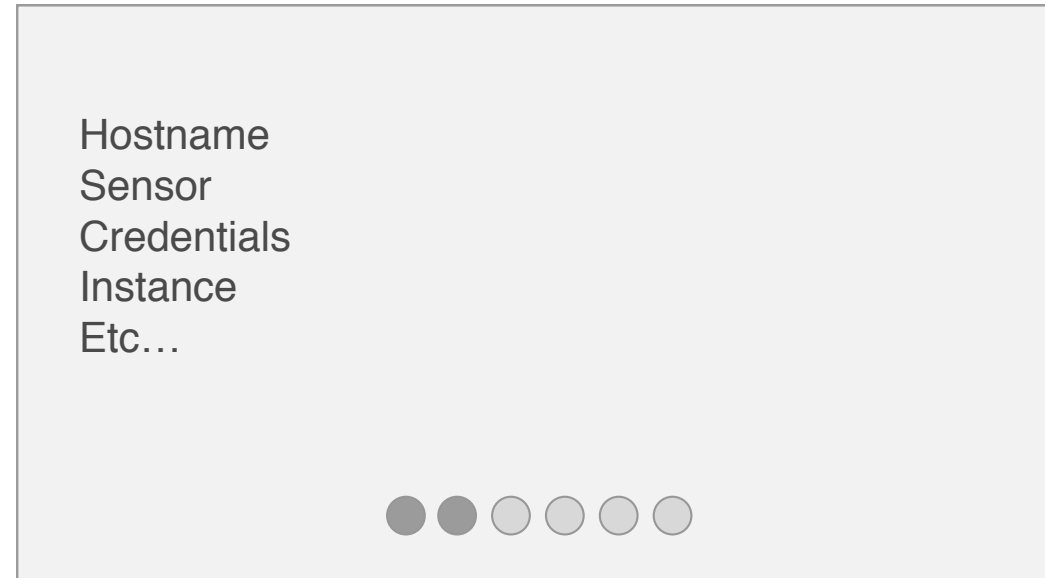

02 - Settings

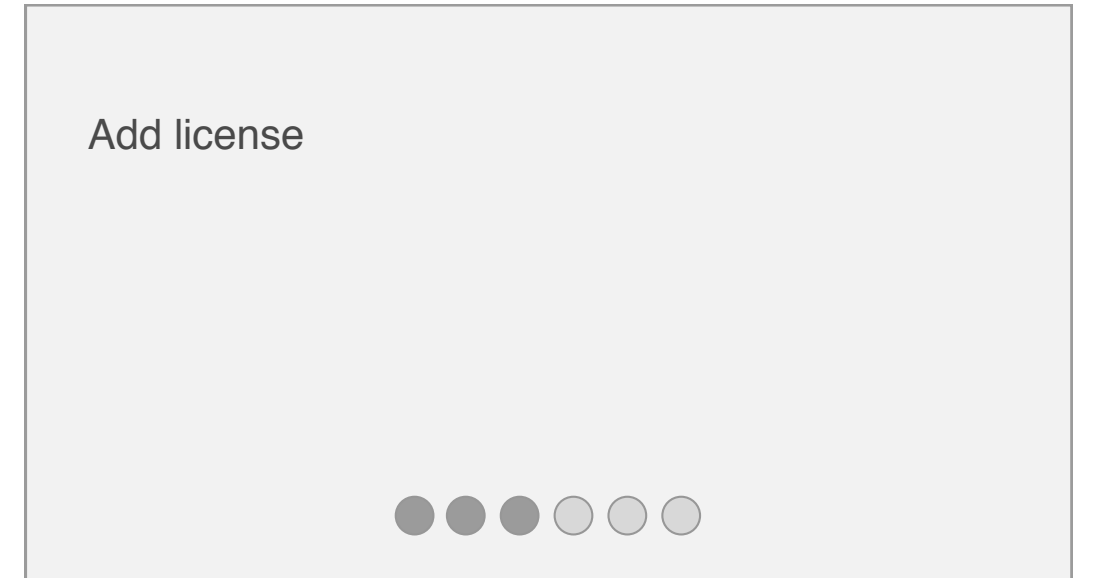

03 - Link license

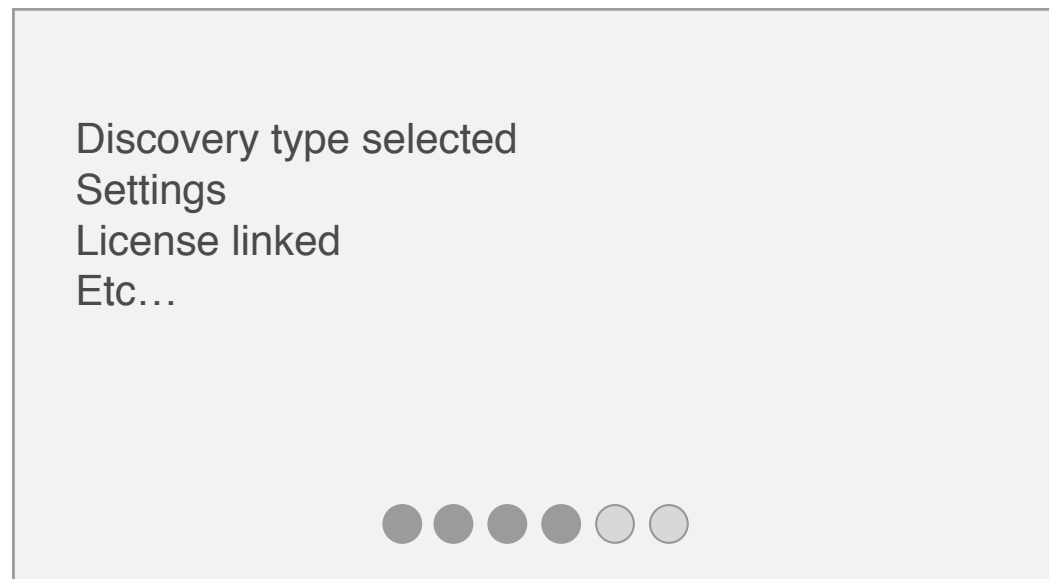

04 - Info review

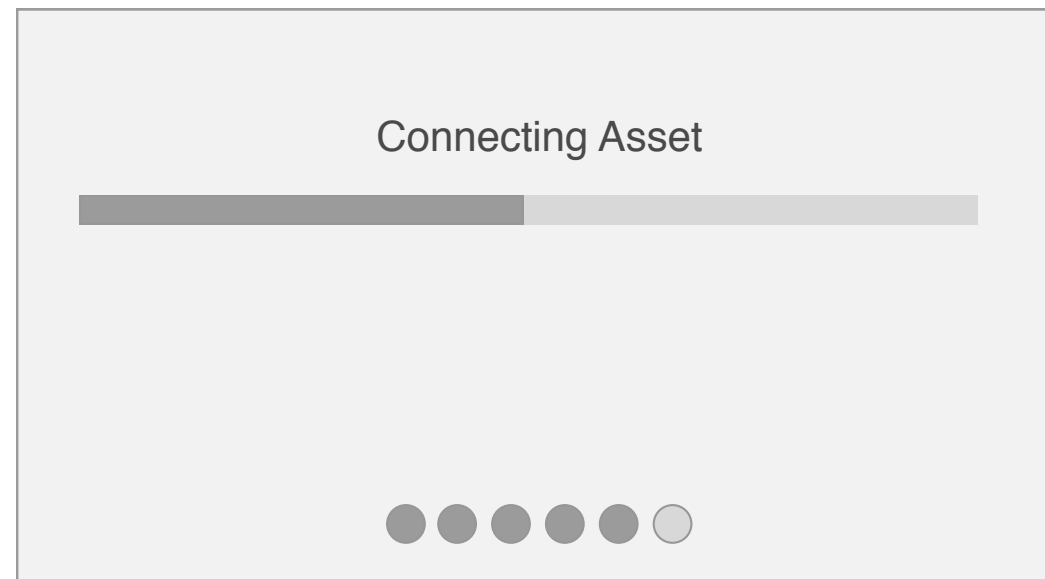

05 - Progress

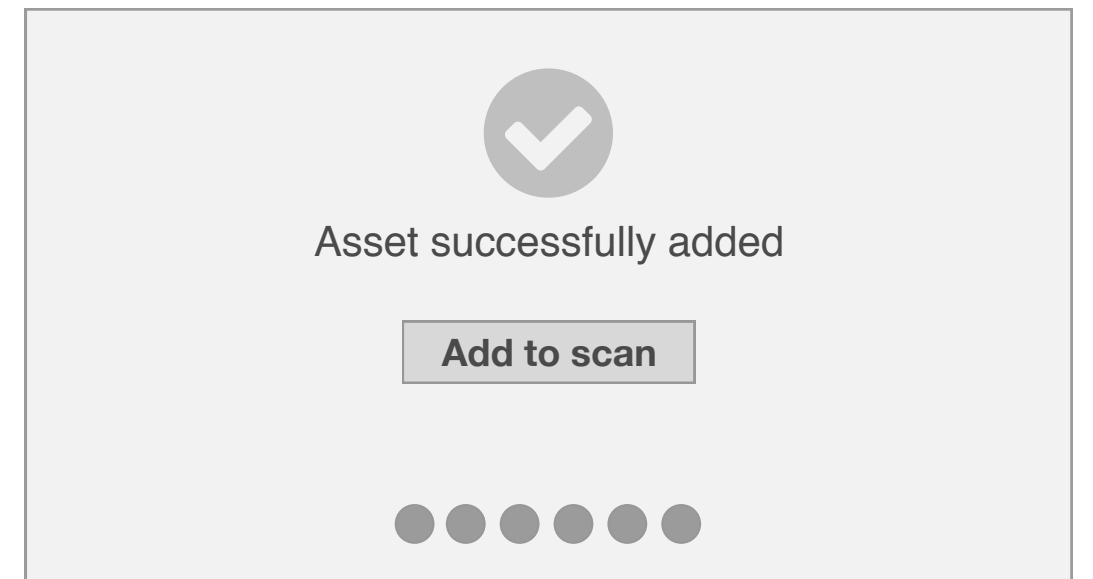

06 - Success/Error Page

2018

DexDex

www.dexdex.io

- User Research
- Product Design
- User Flows
- UI Design
- React (HTML, CSS, Basic JS implementation)

Wallet-to-wallet trading made simple

Dexdex is the the first platform to bring wallet-to-wallet trading directly to your website, wallet, app or dApp. Its API or EasyTrade widget, can offer your users a secure, trust-less way to trade any tokens.

beta

[CHECK OUT THE EASYTRADE WIDGET](#)

Why integrate dexdex?

More tokens than any platform

EasyTrade offers a total of **1327 tokens** tokens, more than any other exchange. New tokens are added



A marketplace for every token

VIEW DEMO

Tokens

1,008

Transactions

1,477

ETH Traded

497.00

USD Traded

135,885

Desktop Wallets



Mobile Wallets



BUY SELL

BUY AMOUNT

0.027316



WALLET

Please, select a wallet

Price

0.036793 ETH / BNB

You will exchange

0.001005 ETH

CONFIRM

Powered by dexdex

By clicking confirm, you agree to our [terms](#)

SELL FLOW

TOTAL AMOUNT TO AUTHORIZE

10,000.000345
Golem (GNT)

- You need to sign the sell approval
- Approval Hash
- You need to sign the sell approval
- Tx Hash

10,000.000345
Golem (GNT)

0xac4484...533a32be
Waiting for mining the network

- You need to sign the sell approval
- Tx Hash

10,000.000345
Golem (GNT)

0xac4484...533a32be
Looking for the best options

- You need to sign the sell approval
- Tx Hash

TOTAL SOLD

10,000.000345 Golem (GNT) ↔ 10,000.000345 Ethereum (ETH)

- You need to sign the sell approval
- 0xac4484...533a32be
- You need to sign the sell approval
- Tx Hash

TOTAL SOLD

10,000.000345 Golem (GNT) ↔ 10,000.000345 Ethereum (ETH)

- You need to sign the sell approval
- 0xac4484...533a32be
- You need to sign the sell approval
- 0x60a1ce...a8c00bff
Waiting for mining the network

TOTAL SOLD

10,000.000345 Golem (GNT) ↔ 10,000.000345 Ethereum (ETH)

- You need to sign the sell approval
- 0xac4484...533a32be
- You need to sign the sell approval
- 0x60a1ce...a8c00bff
Looking for the best options

Transaction Completed

10,000.000345
Golem (GNT)

0x422098bc...684870442a2979c2822f426a7c943858

Transaction details		May 21 2018 07:36:55 AM +UTC
Tx Hash	0x60a1ce...a8c00bff	
Amount bought	10,000.000345	
Golem price	0.000345 ETH	
Network fee	0.000345 ETH	
deduct fee	0.000345 ETH	
Price Optimization	-2.45%	
Total Sent	3.4501 ETH	

TOTAL SENT

10,000.000345
Golem (GNT)

Transaction details		May 21 2018 07:36:55 AM +UTC
Tx Hash	0x60a1ce...a8c00bff	
Amount bought	10,000.000345	
Golem price	0.000345 ETH	
Network fee	0.000345 ETH	
deduct fee	0.000345 ETH	
Price Optimization	-2.45%	
Total Sent	3.4501 ETH	

:(
You rejected us...

Should we start again?

YES, PLEASE

Ohhh!!
There was an error!

Should we start again?

YES, PLEASE

BUY FLOW

TOTAL OBTAINED

10,000.000345 Golem (GNT) ↔ 10,000.000345 Ethereum (ETH)

- You need to sign the sell approval
- Tx Hash

TOTAL OBTAINED

10,000.000345 Golem (GNT) ↔ 10,000.000345 Ethereum (ETH)

- You need to sign the sell approval
- 0xac4484...533a32be
Waiting for mining the network

TOTAL OBTAINED

10,000.000345 Golem (GNT) ↔ 10,000.000345 Ethereum (ETH)

- You need to sign the sell approval
- 0xac4484...533a32be
Looking for the best options

Transaction Completed

10,000.000345
Golem (GNT)

0x422098bc...684870442a2979c2822f426a7c943858

Transaction details		May 21 2018 07:36:55 AM +UTC
Tx Hash	0x60a1ce...a8c00bff	
Amount bought	10,000.000345	
Golem price	0.000345 ETH	
Network fee	0.000345 ETH	
deduct fee	0.000345 ETH	
Price Optimization	-2.45%	
Total Obtained	3.4501 ETH	

TOTAL OBTAINED

10,000.000345
Golem (GNT)

0x422098bc...684870442a2979c2822f426a7c943858

Transaction details		May 21 2018 07:36:55 AM +UTC
Tx Hash	0x60a1ce...a8c00bff	
Amount bought	10,000.000345	
Golem price	0.000345 ETH	
Network fee	0.000345 ETH	
deduct fee	0.000345 ETH	
Price Optimization	-2.45%	
Total Obtained	3.4501 ETH	

:(
You rejected us...

Should we start again?

YES, PLEASE

Ohhh!!
There was an error!

Should we start again?

YES, PLEASE

BASIC ERRORS WIDGET

BUY SELL

BUY AMOUNT: 1000 DAI

SELECT YOUR WALLET: Metamask 1234567 ETH 123.456789 DAI

DAI Price: 0.02332 ETH
Total: 0.0011 ETH
NETWORK FEE: 0.00042 ETH

CONFIRM

BUY SELL

BUY AMOUNT: 1000 BNB

SELECT YOUR WALLET: Metamask 1234567 ETH 123.456789 DAI

DAI Price: 0.02332 ETH
You will exchange: 0.0011 ETH

CONFIRM

BUY SELL

BUY AMOUNT: 1000 DAI

SELECT YOUR WALLET: Metamask 1234567 ETH 123.456789 DAI

DAI Price: 0.02332 ETH
Total: 0.0011 ETH
NETWORK FEE: 0.00042 ETH

CONFIRM

BUY SELL

BUY AMOUNT: Invalid Amount

1 DAI

SELECT YOUR WALLET: Metamask 1234567 ETH 123.456789 DAI

DAI Price: 0.02332 ETH
Total: 0.0011 ETH
NETWORK FEE: 0.00042 ETH

CONFIRM

Steps

WORKING...

10,000.000345 TokenA (TKA) ↔ 1,000345 Ethereum (ETH)

- You need to sign the sell approval
- 0xac4484...533a32be
Waiting for mining the network

TOTAL RECEIVED

10,000.000345 TokenA (TKA) | 1,000345 Ethereum (ETH)

Transaction details		May 21 2018 07:36:55 AM +UTC
Account	0x60a1ce...a8c00bff	
Transaction	0.000345 ETH	
TKA Price	0.000345 ETH	
Network Cost	0.000345 ETH	
Amount Obtained	-2.45%	
Total Sent	0.000345 ETH	
Service Fee	-2.45%	
Refund	-2.45%	

TOTAL RECEIVED

10,000.000345 TokenA (TKA) → 1,000345 Ethereum (ETH)

Transaction details		May 21 2018 07:36:55 AM +UTC
Account	0x60a1ce...a8c00bff	
Transaction	0.000345 ETH	
TKA Price	0.000345 ETH	
Network Cost	0.000345 ETH	
Amount Obtained	-2.45%	
Total Sent	0.000345 ETH	
Service Fee	-2.45%	
Refund	-2.45%	

TOTAL SENT

1,000345 Ethereum (ETH) → 10,000.000345 TokenA (TKA)

Transaction details		May 21 2018 07:36:55 AM +UTC
Account	0x60a1ce...a8c00bff	
Transaction	0.000345 ETH	
TKA Price	0.000345 ETH	
Network Cost	0.000345 ETH	
Amount Obtained	-2.45%	
Total Sent	0.000345 ETH	
Service Fee	-2.45%	
Refund	-2.45%	

TOTAL SENT

10,000.000345 TokenA (TKA) → 1,000345 Ethereum (ETH)

Transaction details		May 21 2018 07:36:55 AM +UTC
Account	0x60a1ce...a8c00bff	
Transaction	0.000345 ETH	
TKA Price	0.000345 ETH	
Network Cost	0.000345 ETH	
Amount Obtained	-2.45%	
Total Sent	0.000345 ETH	
Service Fee	-2.45%	
Refund	-2.45%	

TOTAL SENT

10,000.000345 TokenA (TKA) → 1,000345 Ethereum (ETH)

Transaction details		May 21 2018 07:36:55 AM +UTC
Account	0x60a1ce...a8c00bff	
Transaction	0.000345 ETH	
TKA Price	0.000345 ETH	
Network Cost	0.000345 ETH	
Amount Obtained	-2.45%	
Total Sent	0.000345 ETH	
Service Fee	-2.45%	
Refund	-2.45%	

TRANSACTION SUCCESSFUL

1,000345 Ethereum (ETH) → 10,000.000345 TokenA (TKA)

Transaction details		May 21 2018 07:36:55 AM +UTC
Account	0x60a1ce...a8c00bff	
Transaction	0.000345 ETH	
TKA Price	0.000345 ETH	
Network Cost	0.000345 ETH	
Amount Obtained	-2.45%	
Total Sent	0.000345 ETH	
Service Fee	-2.45%	
Refund	-2.45%	

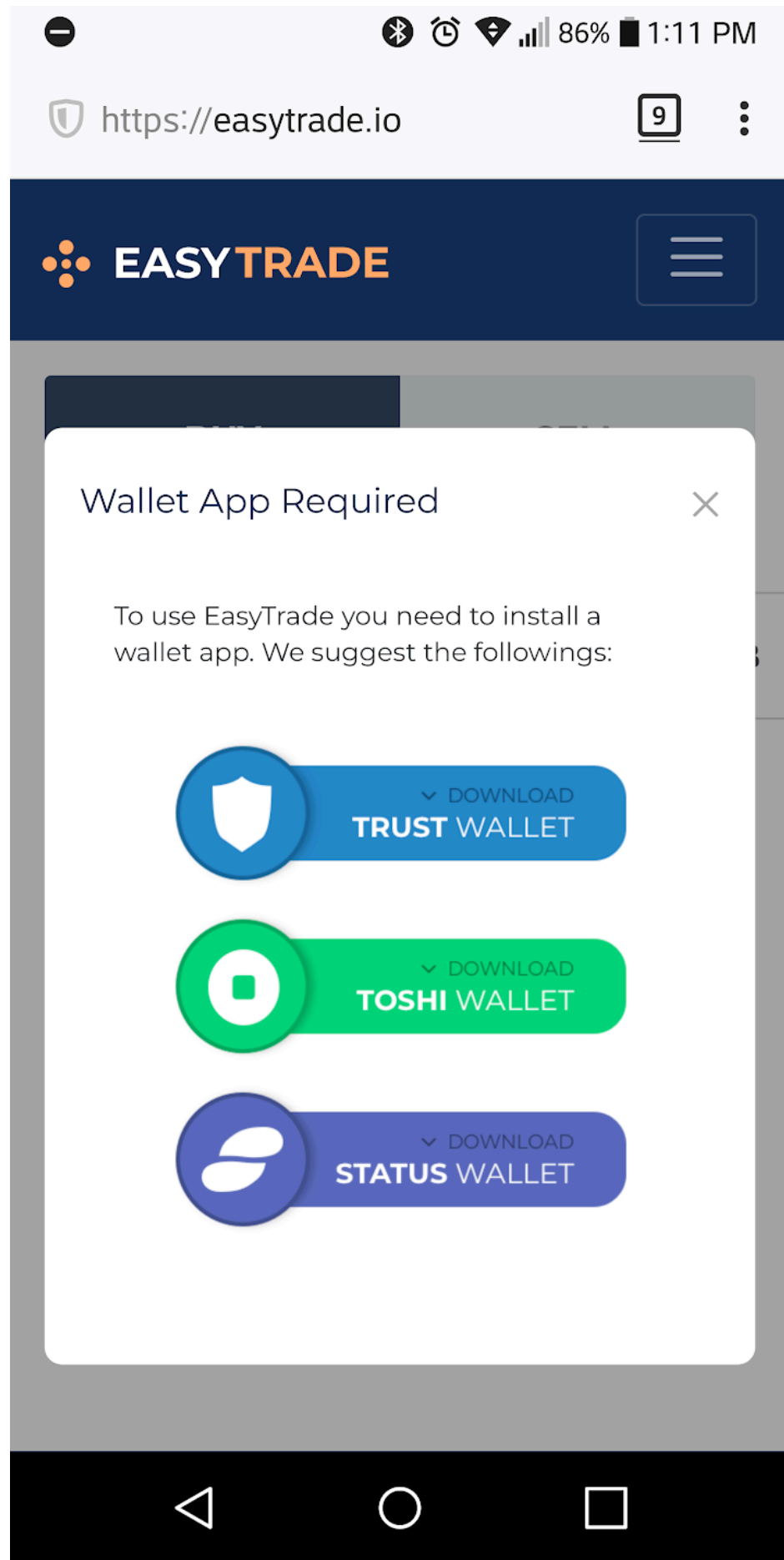

Firefox Mobile

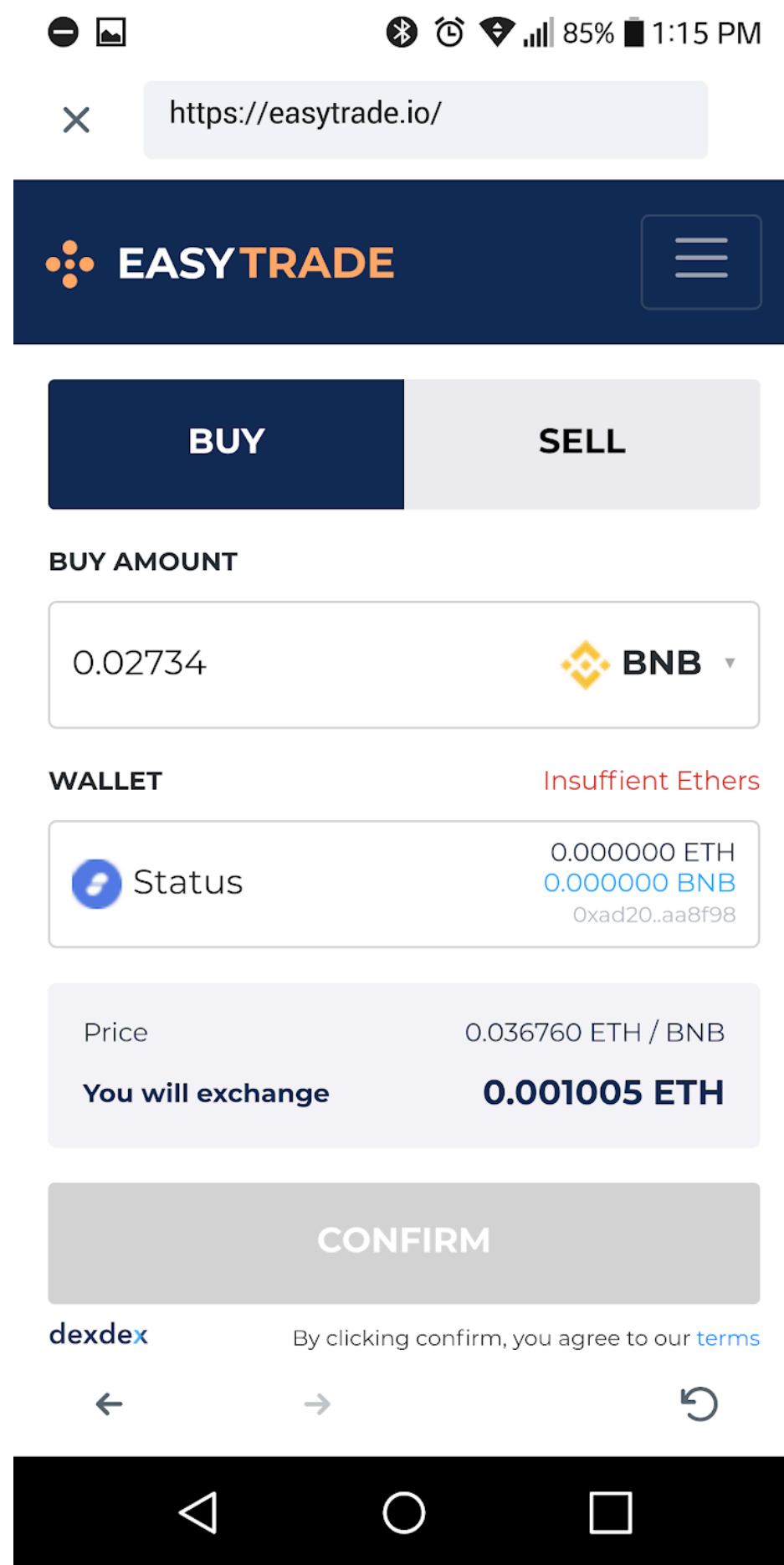

Status

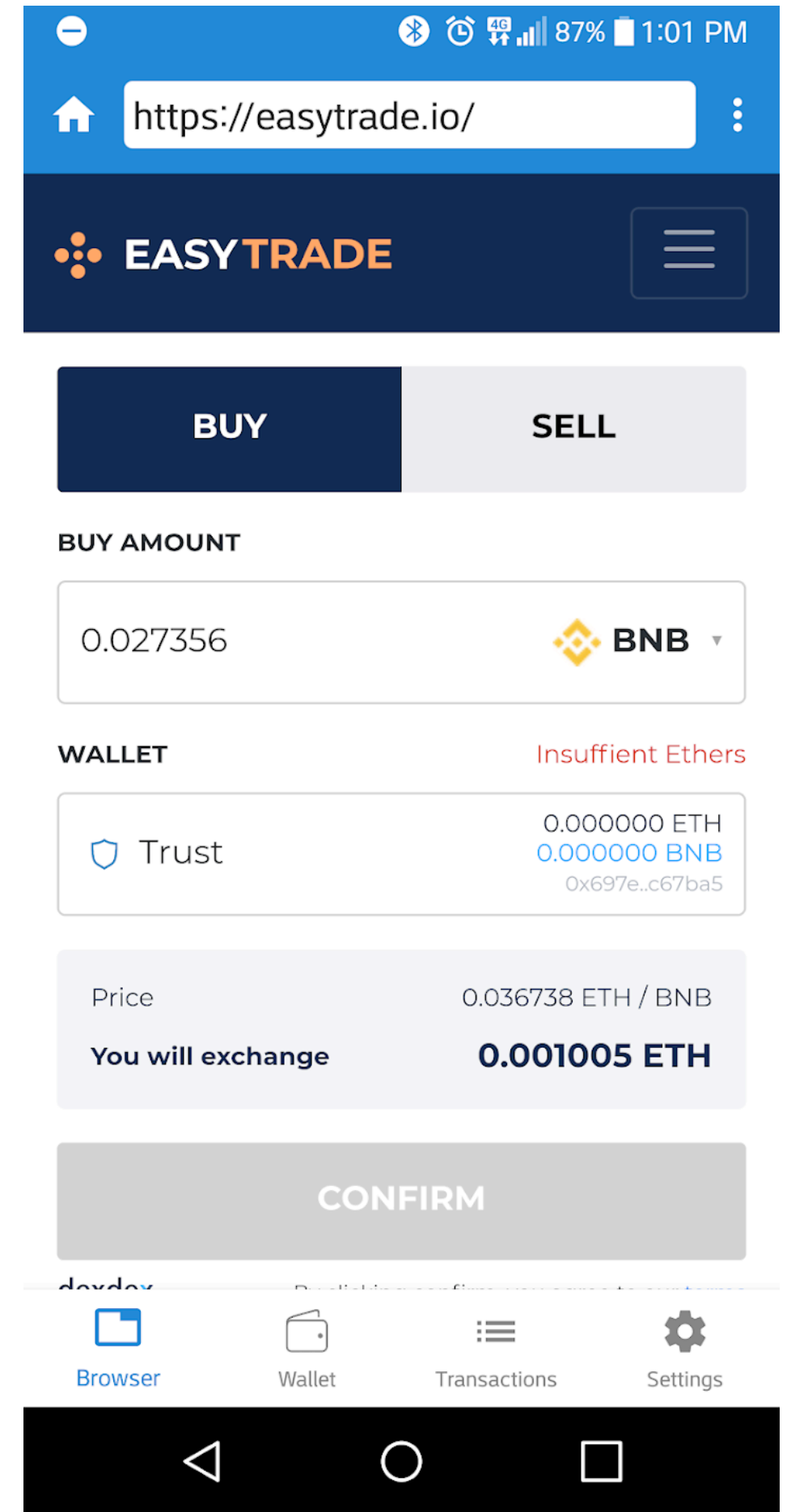

Trust

   sebazelonka